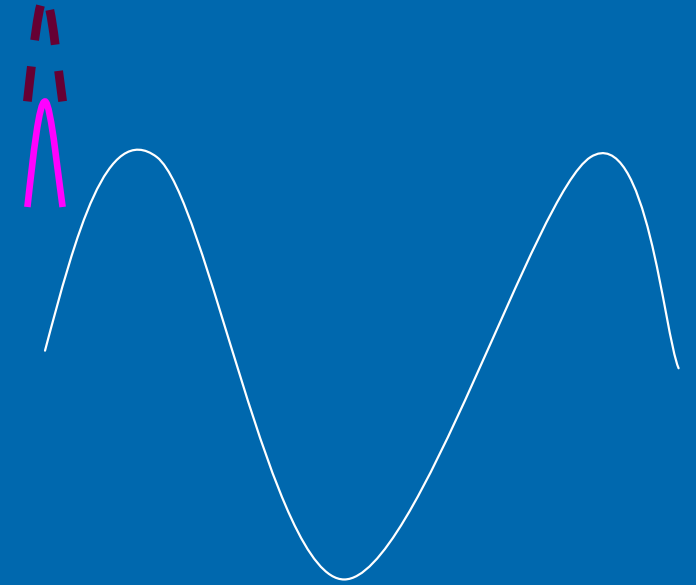
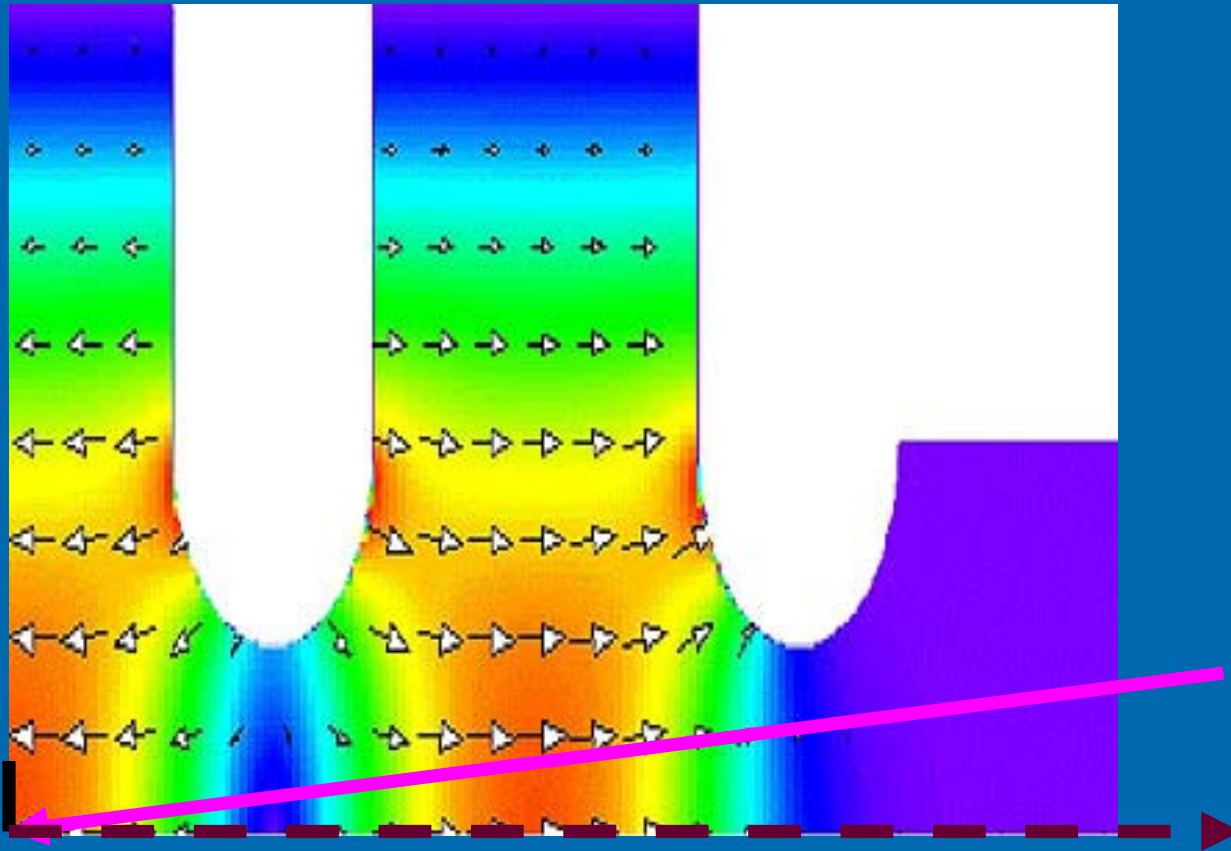
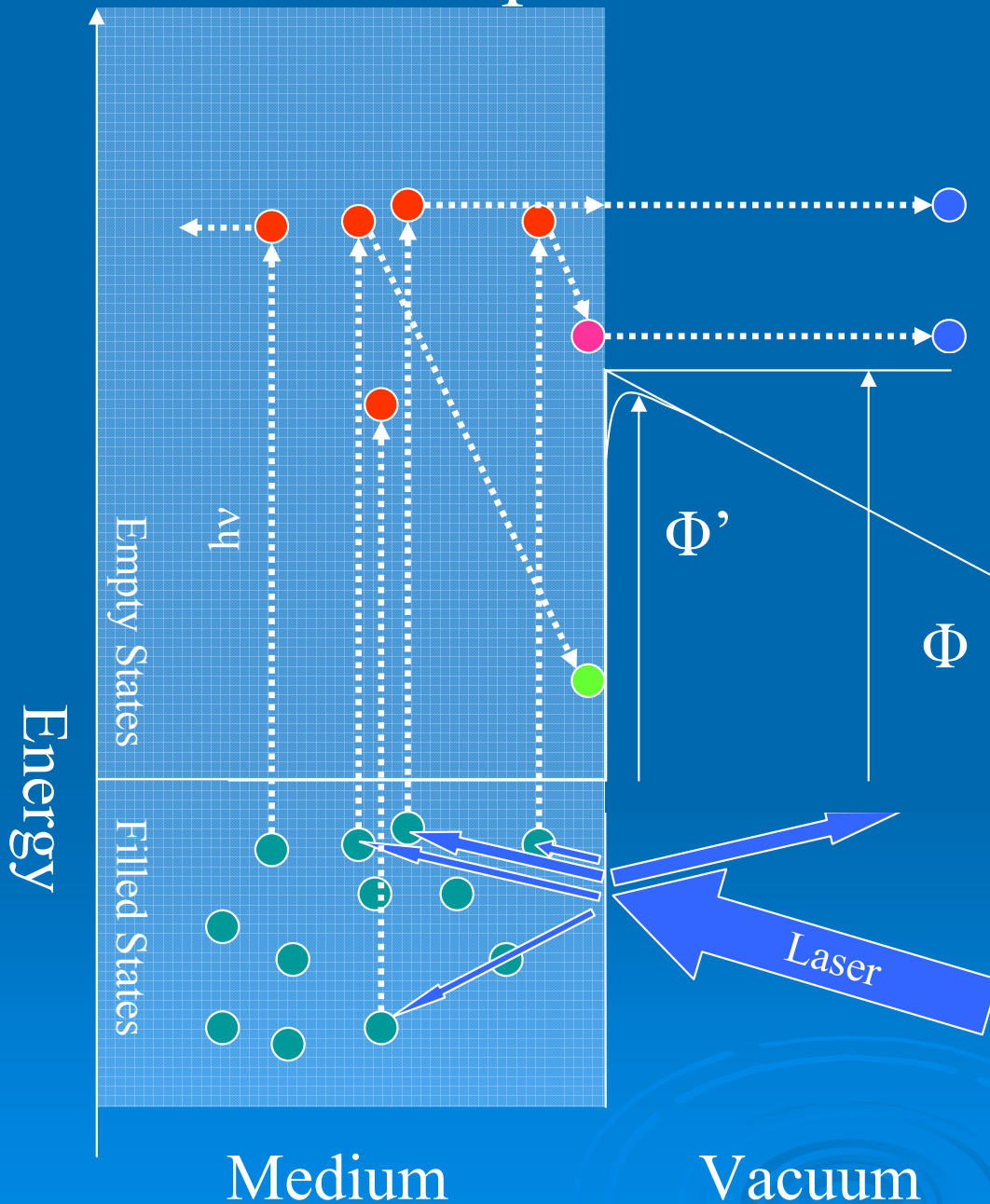

Photo injector Principle



Choice of
Cathode material
Laser
Accelerating field: Time structure

Three Step Model of Photoemission in metal



- 1) Excitation of e^- in metal
 - Reflection
 - Absorption of light
 - Energy distribution of excited e^-
- 2) Transit to the Surface
 - e^-e^- scattering
 - Direction of travel
- 3) Escape surface
 - Overcome Workfunction
 - Reduction of Φ due to applied field (Schottky Effect)

Integrate product of probabilities over all electron energies capable of escape to obtain Quantum Efficiency

Step 1 – Absorption and Excitation

Fraction of light absorbed:

$$I_{\text{ab}}/I = (1-R)$$

Probability of absorption and electron excitation:

$$P(E, h\nu) = \frac{N(E)N(E-h\nu)}{E_f + h\nu} \int_{E_f} N(E')N(E'-h\nu)dE'$$

- Medium thick enough to absorb all transmitted light
- Only energy conservation invoked, conservation of k vector is not an important selection rule

Step 2 – Probability of reaching the surface w/o e⁻-e⁻ scattering

$$T(E, \nu) = \frac{\lambda_e(E) / \lambda_{ph}(\nu)}{1 + \lambda_e(E) / \lambda_{ph}(\nu)}$$

- Energy loss dominated by e-e scattering
- Only unscattered electrons can escape

Step 3 - Escape Probability

- Criteria for escape: $\frac{\hbar^2 k_{\perp}^2}{2m} > E_T = E_f + \phi$

- Requires electron trajectory to fall within a cone defined by angle:

$$\cos \theta = \frac{k_{\perp \min}}{|\vec{k}|} = \left(\frac{E_T}{E}\right)^{1/2}$$

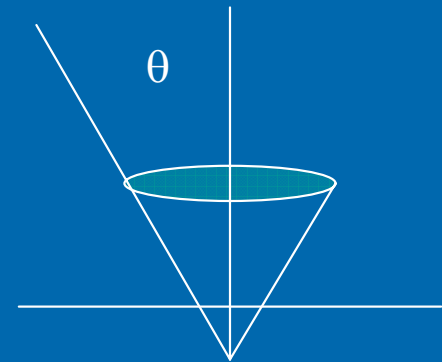

- Fraction of electrons of energy E falling with the cone is given by:

$$D(E) = \frac{1}{4\pi} \int_0^{\theta} \sin \theta' d\theta' \int_0^{2\pi} d\phi = \frac{1}{2} (1 - \cos \theta) = \frac{1}{2} \left(1 - \left(\frac{E_T}{E}\right)^{1/2}\right)$$

- For small values of $E - E_T$, this is the dominant factor in determining the emission. For these cases:

$$QE(\nu) \propto \int_{\phi + E_f}^{\hbar\nu + E_f} D(E) dE = \int_{E_T}^{(\hbar\nu - \phi) + E_T} D(E) dE$$

- This gives:

$$QE(\nu) \propto (\hbar\nu - \phi)^2$$

Schottky Effect

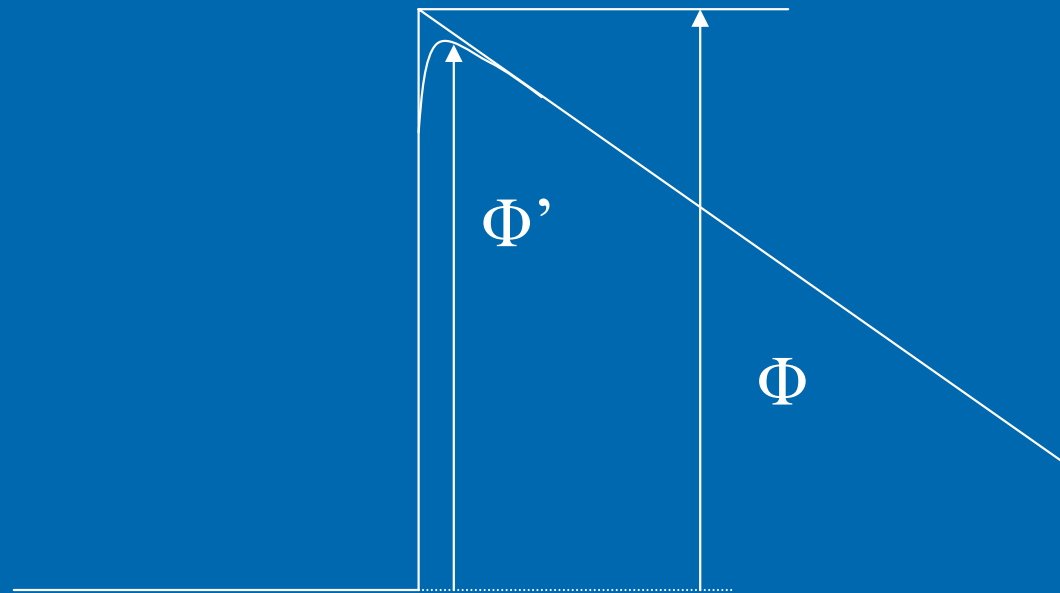

$$\Phi' \text{ (eV)} = \Phi - 3.7947 \cdot 10^{-5} \sqrt{E}$$

$$= \Phi - 3.7947 \cdot 10^{-5} \sqrt{\beta E} \quad \text{If field is enhanced}$$

$$\sqrt{QE} = (1 - R)(h\nu - \phi_0 + \alpha \sqrt{\beta E}) \quad \text{near photoemission threshold}$$

Slope and intercept at two wavelengths determine Φ and β uniquely

EDC and QE

At this point, we have $N(E, h\nu)$ - the Energy Distribution Curve of the emitted electrons

Yield:

$$Y(\nu) = I(\nu)(1 - R(\nu)) \int_{\phi + E_f}^{h\nu + E_f} P(E)T(E, \nu)D(E)dE$$

Quantum efficiency:

$$QE(\nu) = (1 - R(\nu)) \int_{\phi + E_f}^{h\nu + E_f} P(E)T(E, \nu)D(E)dE$$

Typical metals:

Copper, Magnesium—Tested successfully in RT RF injectors

Niobium, lead— Tested successfully in SC RF guns

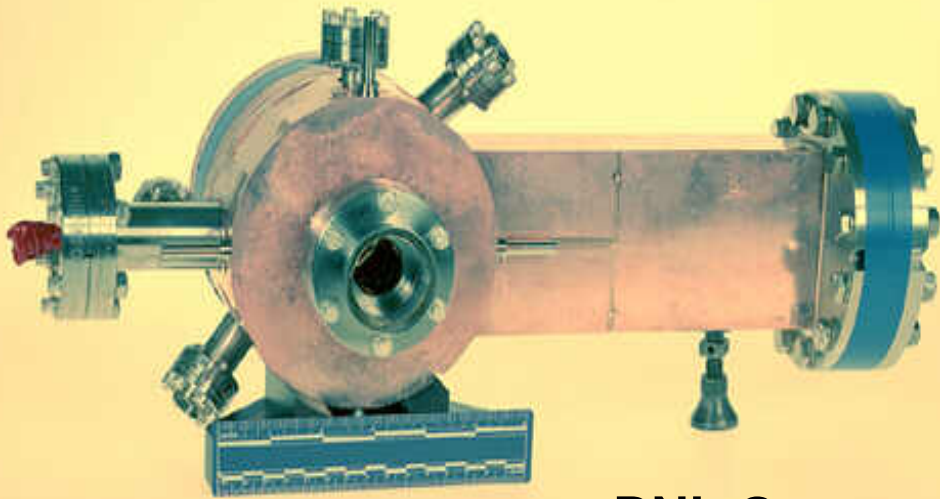

BNL Gun



SRF gun w Nb cathode

Cathode preparation

- Procure High purity metal from commercial vendor
- Polish using commercial diamond slurry
- Avoid exposure to oxygen containing cleaners
- Rinse in hexane
- Clean in ultrasonicator in hexane bath
- Transport to vacuum chamber in hexane bath
- Bake and pump
- Laser/ion clean in 10^{-9} Torr vacuum

Niobium cathode — QE vs. laser cleaning

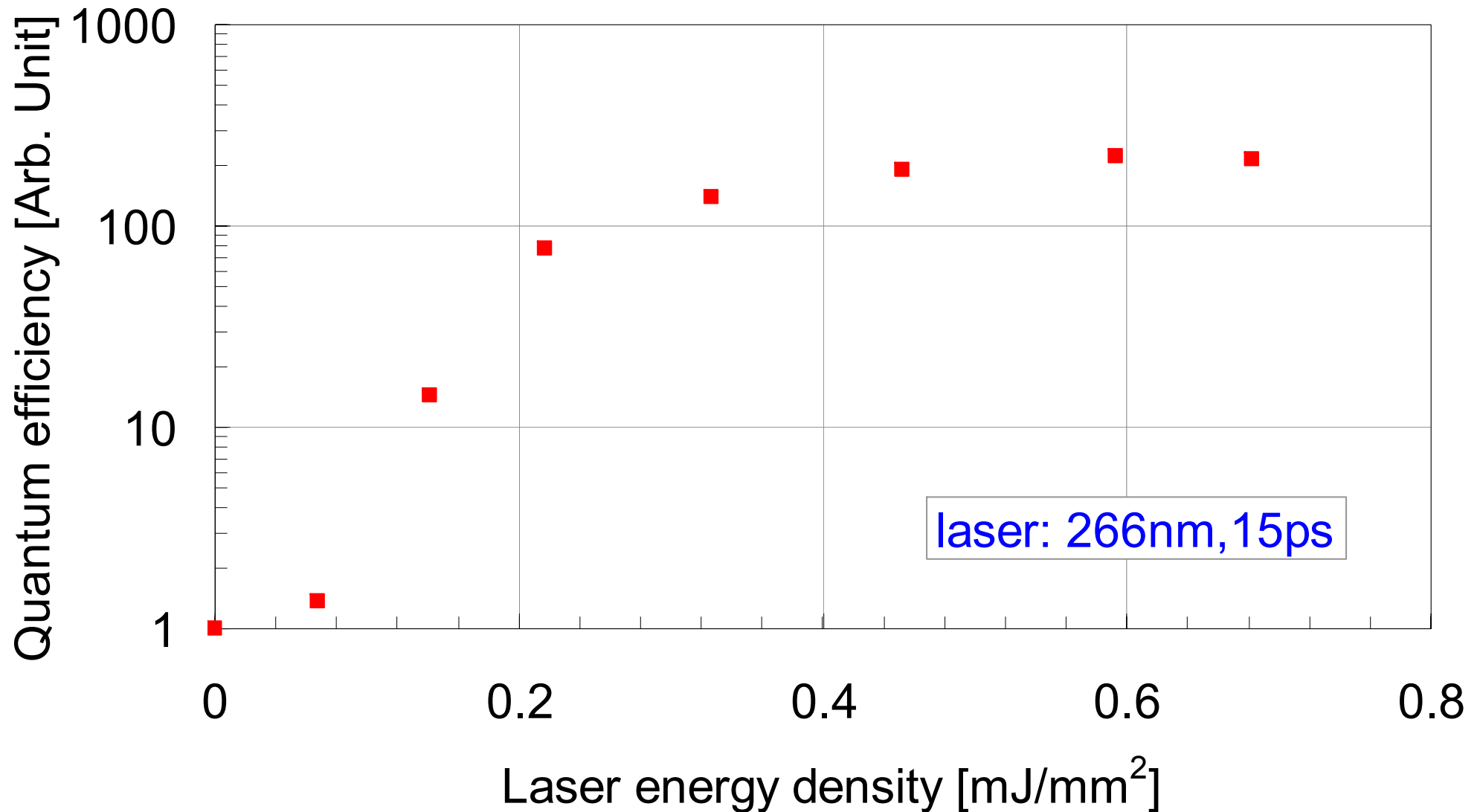

H Ion Beam Cleaning

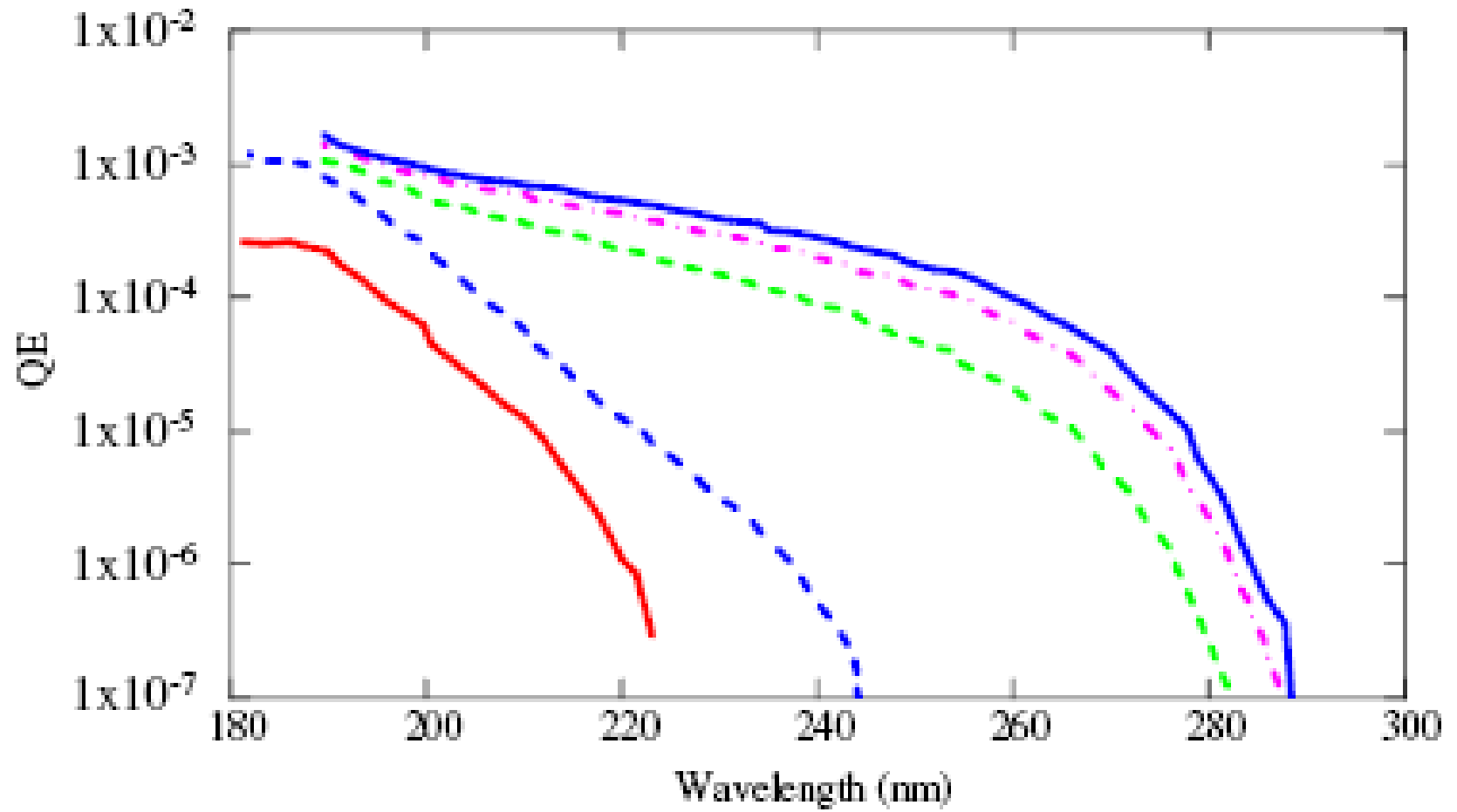

- initial
- - - 0.63mC
- - - 2.07mC
- · - 3.03mC
- 10.23mC

Advantages

- ✓ Prompt emission
- ✓ Easy preparation
- ✓ Long lifetime
- ✓ Tolerant to contaminants
- ✓ In situ rejuvenation
- ✓ Wide choice

Disadvantages

- Low QE
- UV wavelength
 - Complicated laser system
 - Low average current

LCLS Laser System Overview

- Ti:Sapphire Choice:**
- high bandwidth available
 - high average power output
 - stable, industrial standard for broadband

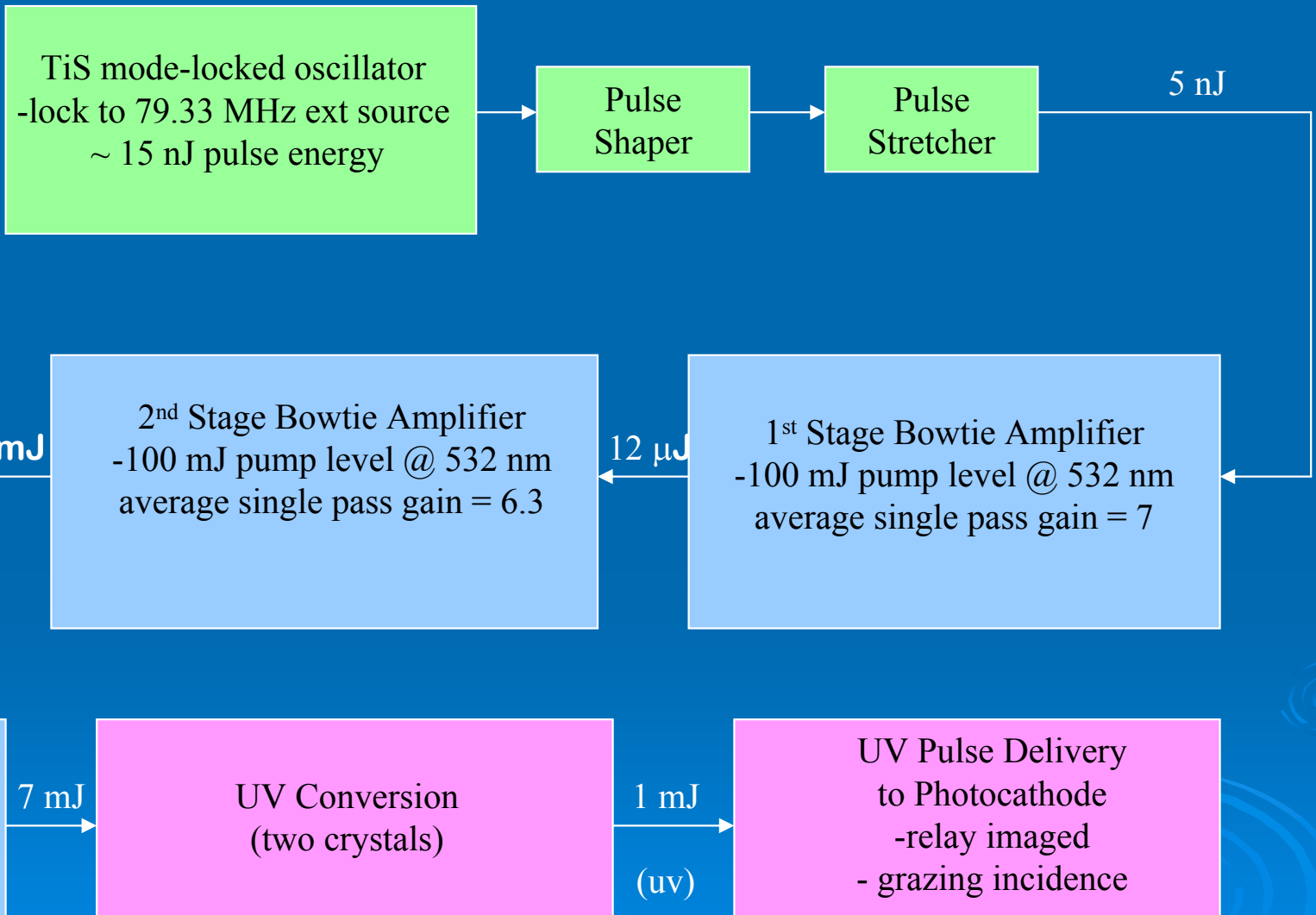

ATF Nd: YAG Laser - Functional Units and Beam path

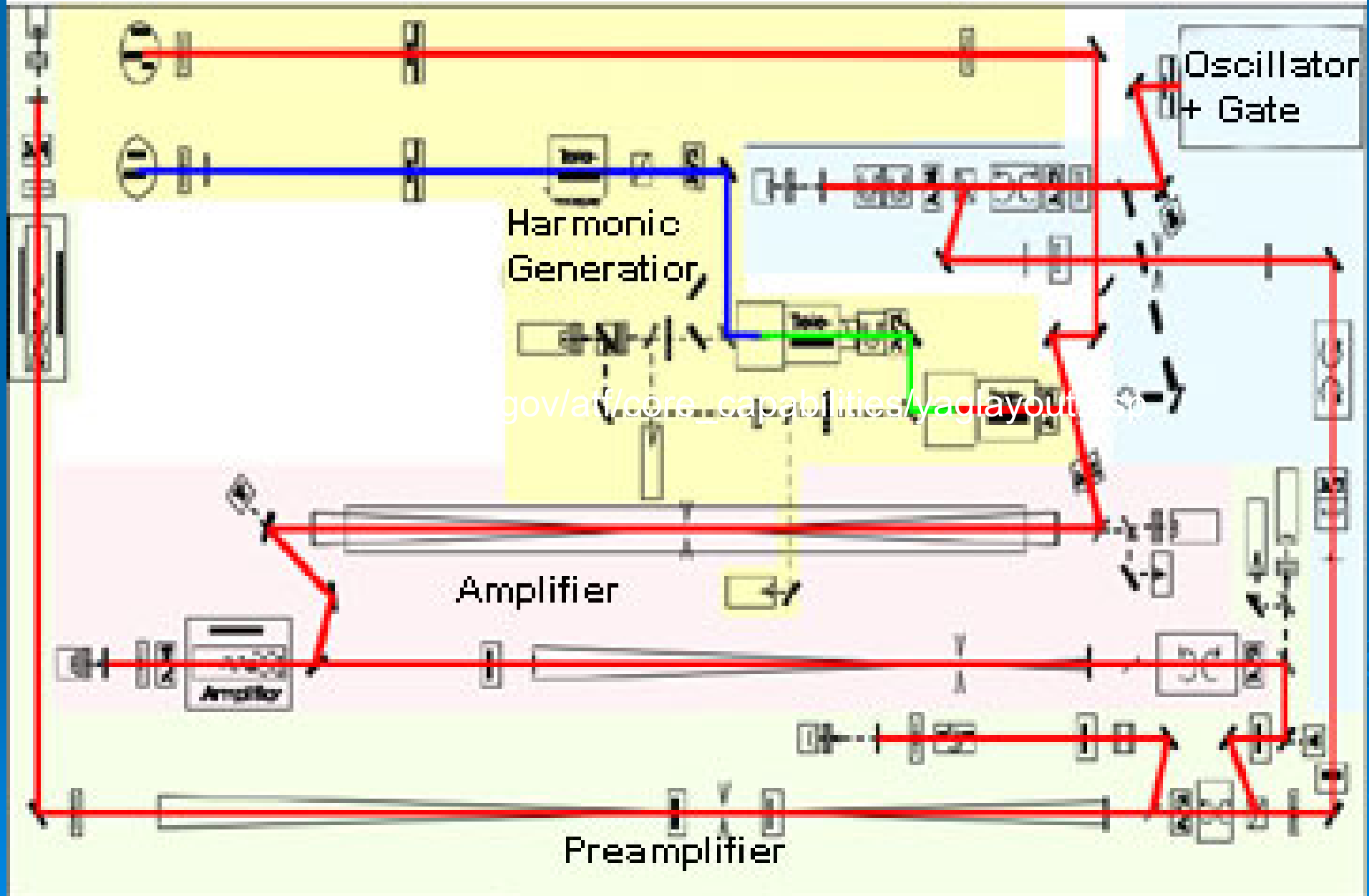

Semiconductor photocathodes

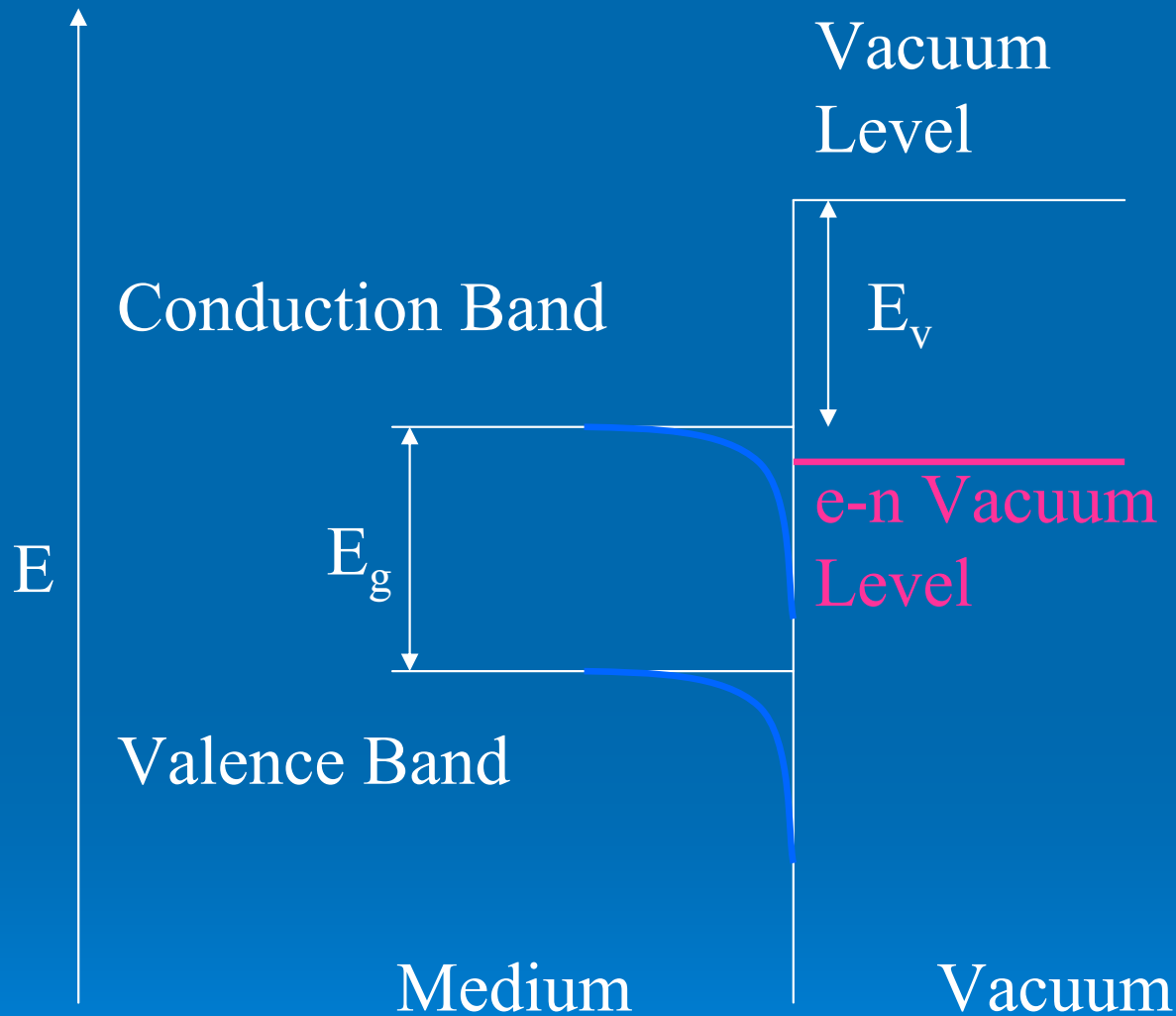

Three step model still valid

$$E_g + E_v < 2 \text{ eV}$$

Low e population in CB

Band Bending

Electronegative surface layer

Three Step Model of Photoemission - Semiconductors

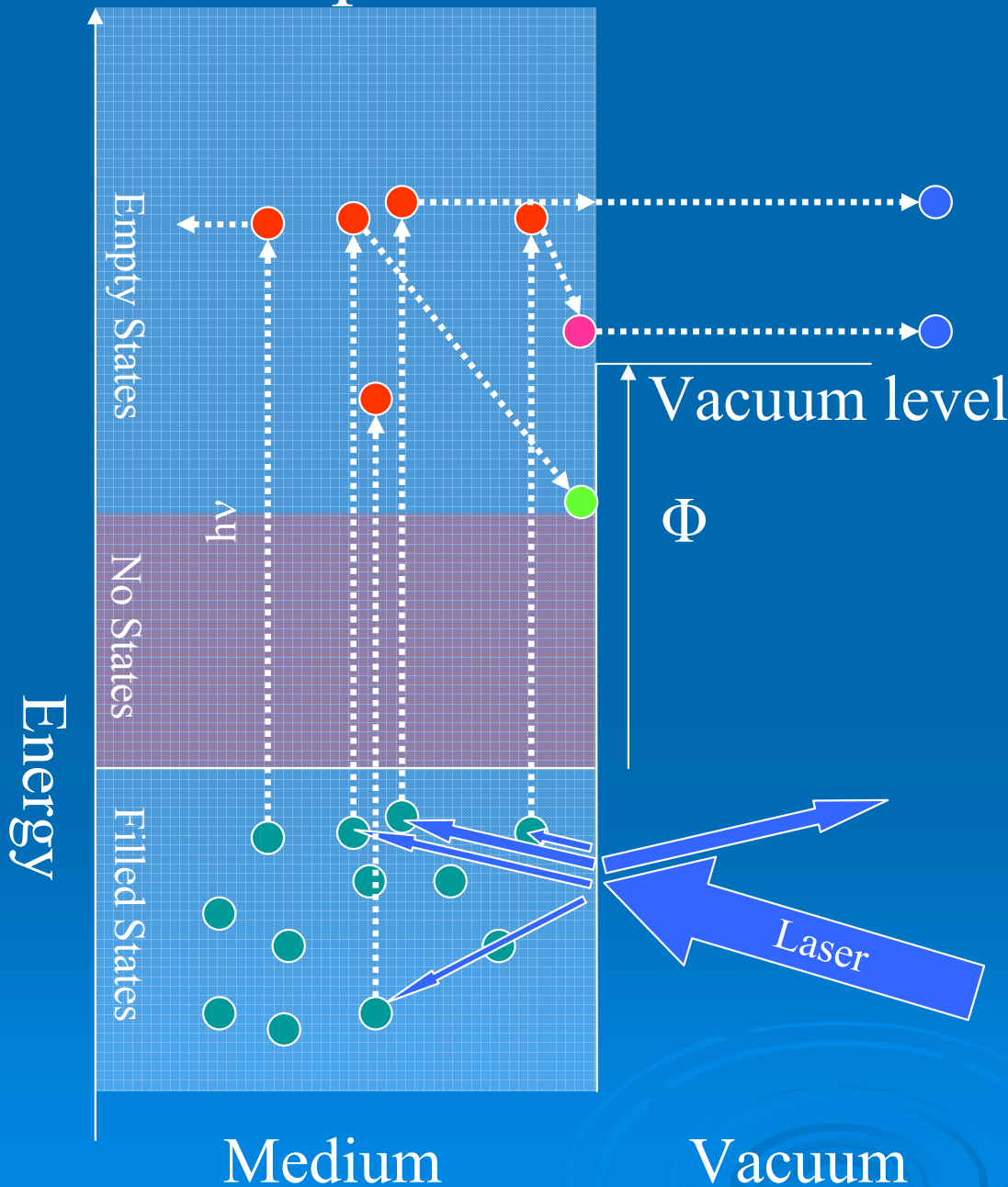

- 1) Excitation of e^-
Reflection, Transmission,
Interference
Energy distribution of excited e^-
- 2) Transit to the Surface
 e^- -phonon scattering
 e^-e^- scattering
Random Walk
- 3) Escape surface
Overcome Workfunction

Need to account for Random Walk in cathode suggests Monte Carlo modeling

Typical materials :

- Multi alkali

 - K_2CsSb , Cs_2Te used in RT RF injectors

- GaAs:Cs used in DC guns



			TTF specs
synchronized	~1 dg of RF cycle	~2 ps @1.3 GHz	< 1 ps rms
longitudinal and transverse size	~5 dg == ~ 10 ps	field uniformity ~ some mm	length 20 ps, Ø = 3 mm
charge of ~1 nC per bunch required	Cs ₂ Te cathode QE ~ 1...10% (UV)	~1 µJ/pulse@UV	factor of ~10 overhead
long trains of pulses with low rep rate	trains 800 µs long with up to 7200 pulses (9 MHz) @ 10 Hz		

Laser System for Cs₂Te Cathode

In cooperation of DESY and Max-Born-Institute, Berlin,
I. Will et al., NIM A541 (2005) 467,
S. Schreiber et al., NIM A445 (2000)

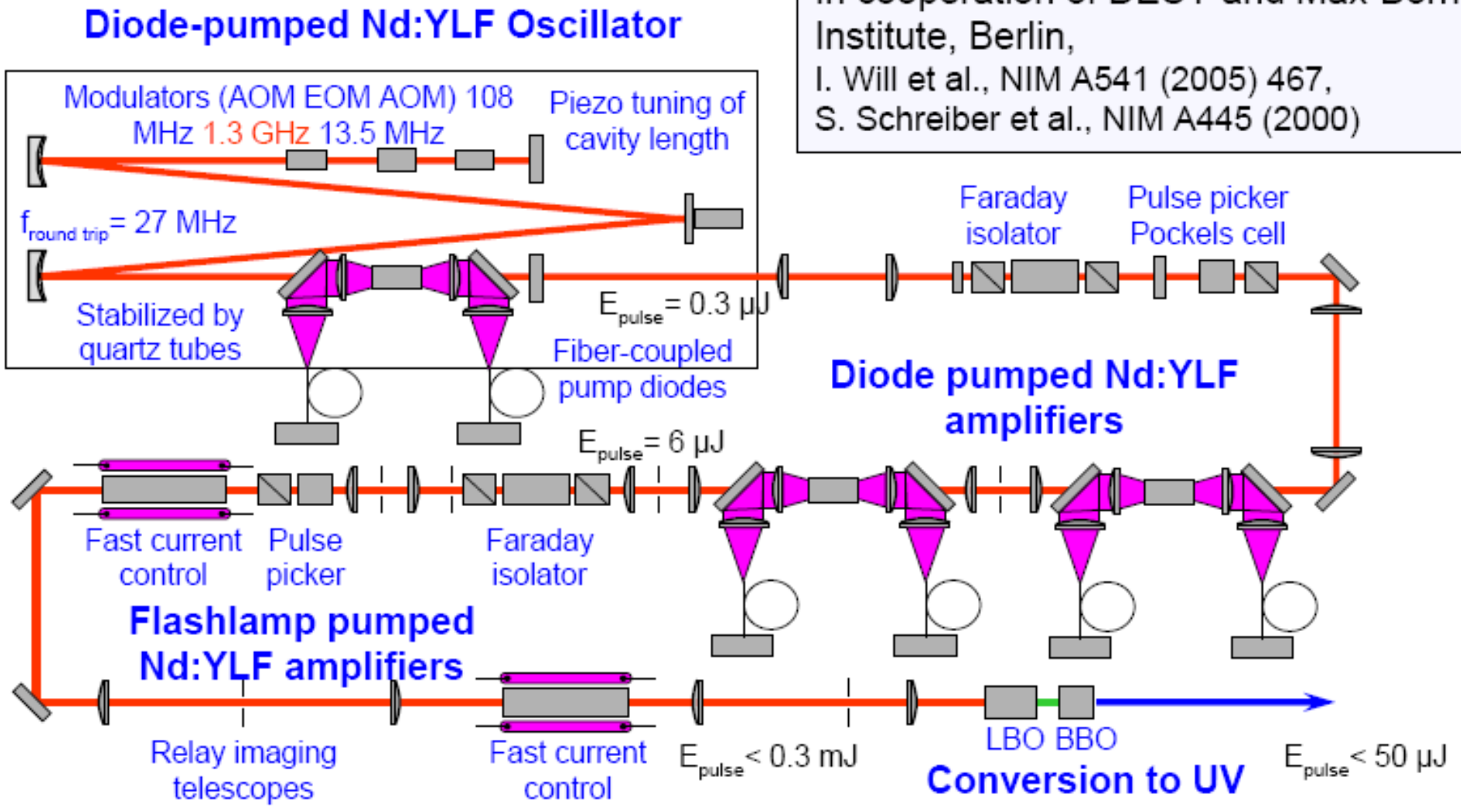

TTF Laser System: Oscillator

- Mode-locked pulsed oscillator:
 - diode pumped (32 W)
- Synchronized to 1.3 GHz from the master oscillator, stabilized with quartz rods
 - 1.3 GHz EO modulator with two AOM
 - phase stability 0.2 ps rms
 - pulse length 12 ps fwhm
- 27 MHz pulse train
 - length 2.5 ms, pulsed power 7 W
 - pulse picker up to 3 MHz

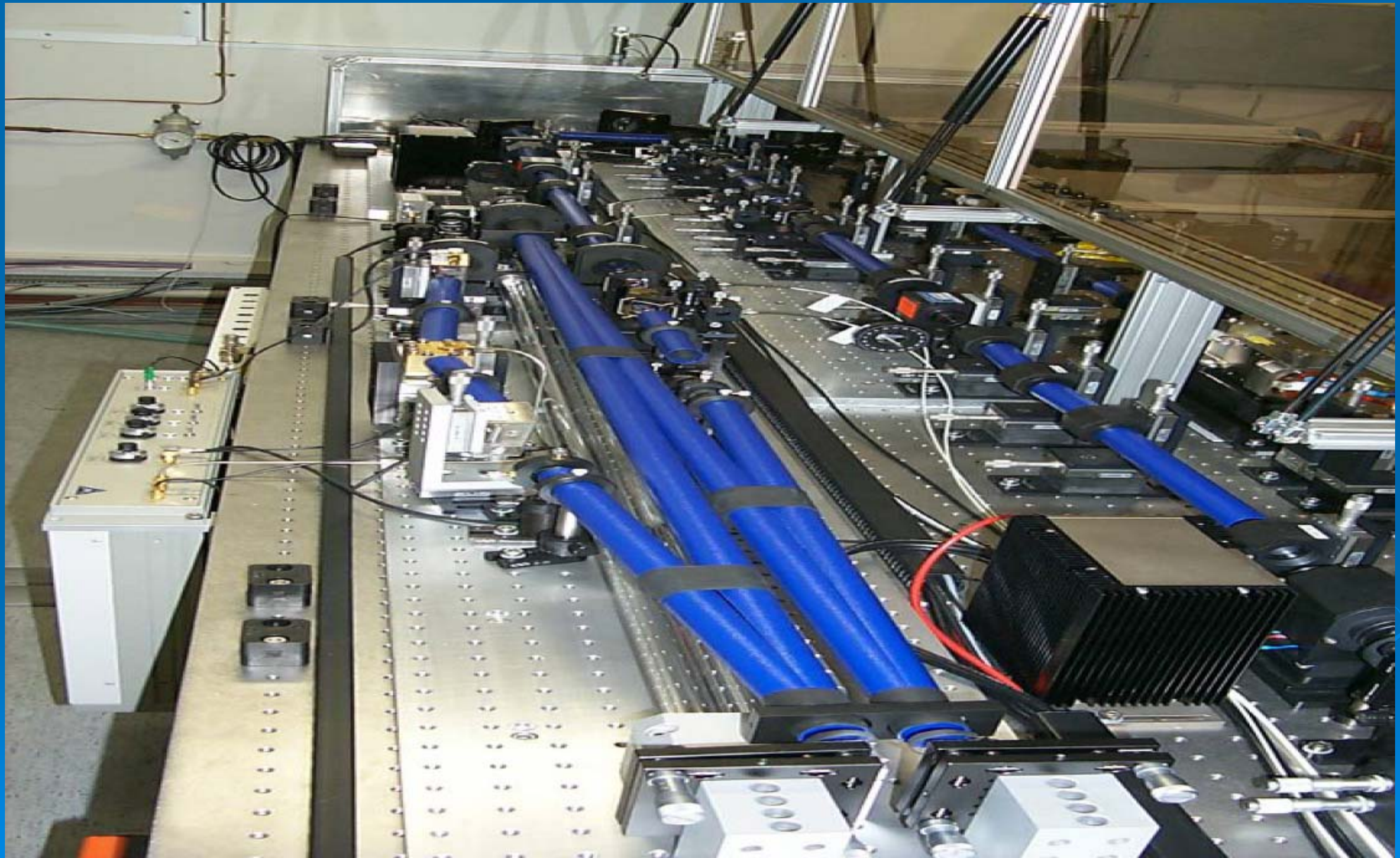

Amplifiers

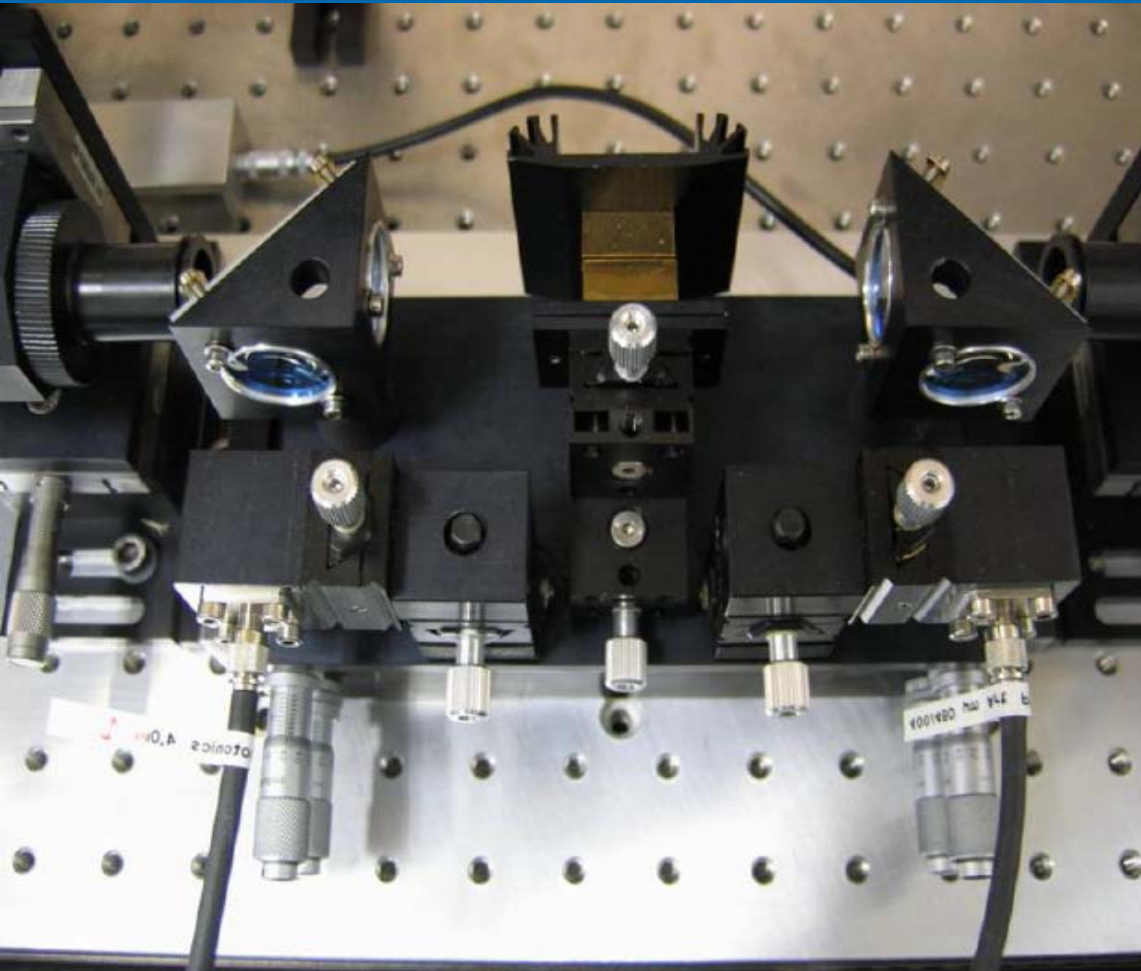

Laser diodes:

- 32 W pulsed, 805 nm
- end pumped through fibers
- energy from 0.3 μJ to 6 μJ /pulse

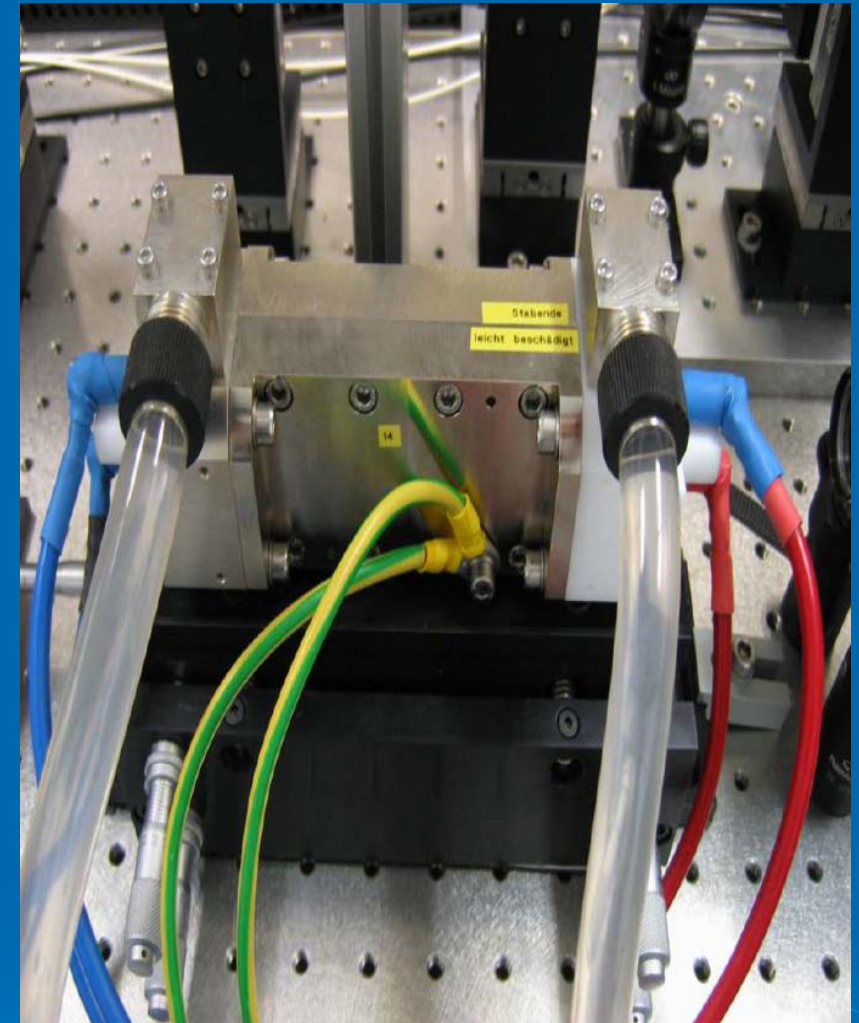

Flashlamps:

- cheap, powerful (pulsed, 50 kW electrical/head)
- current control with IGPT switches
- allows flat pulse trains
- energy up to 300 μJ (1 MHz), 140 μJ (3 MHz)

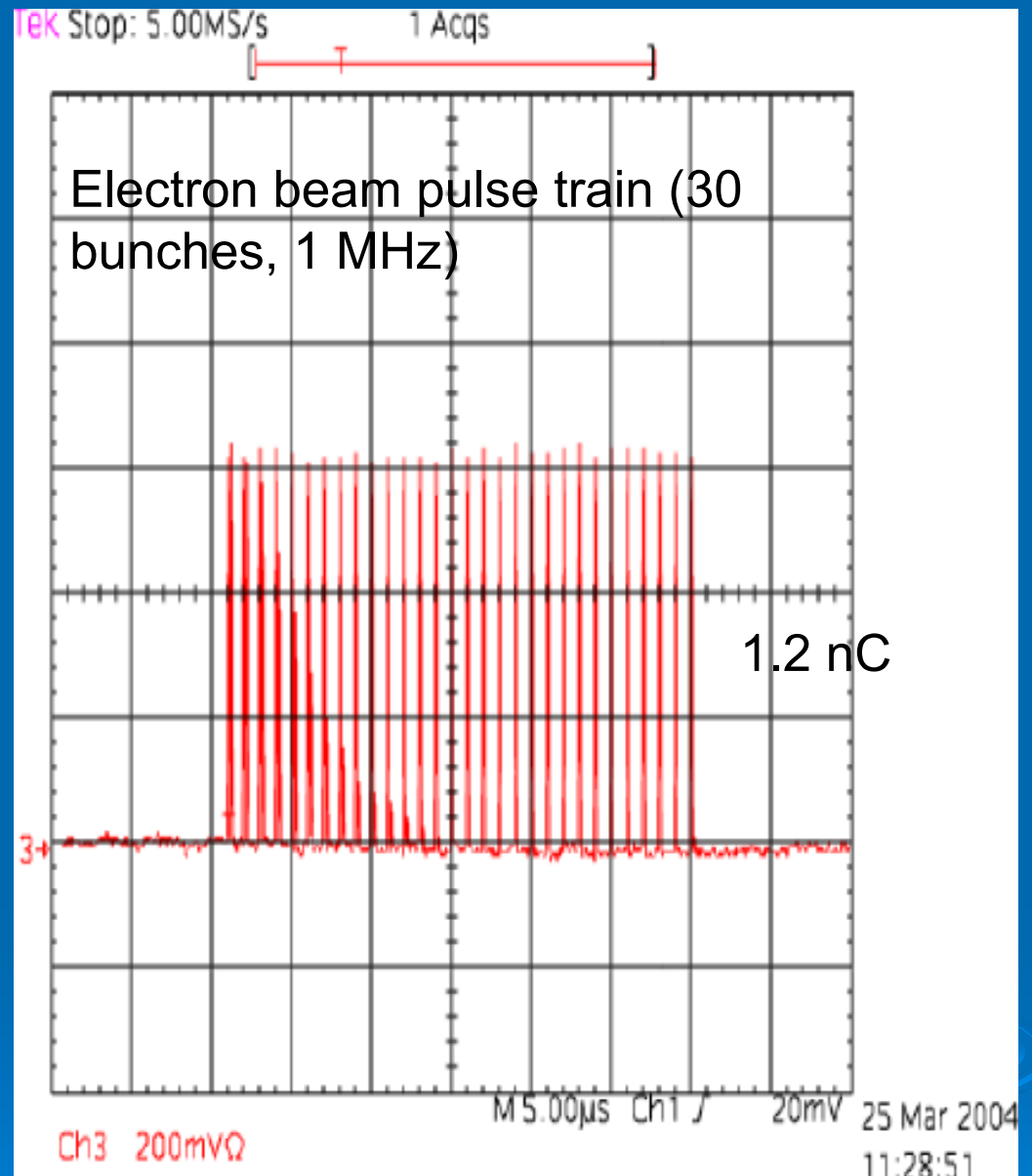
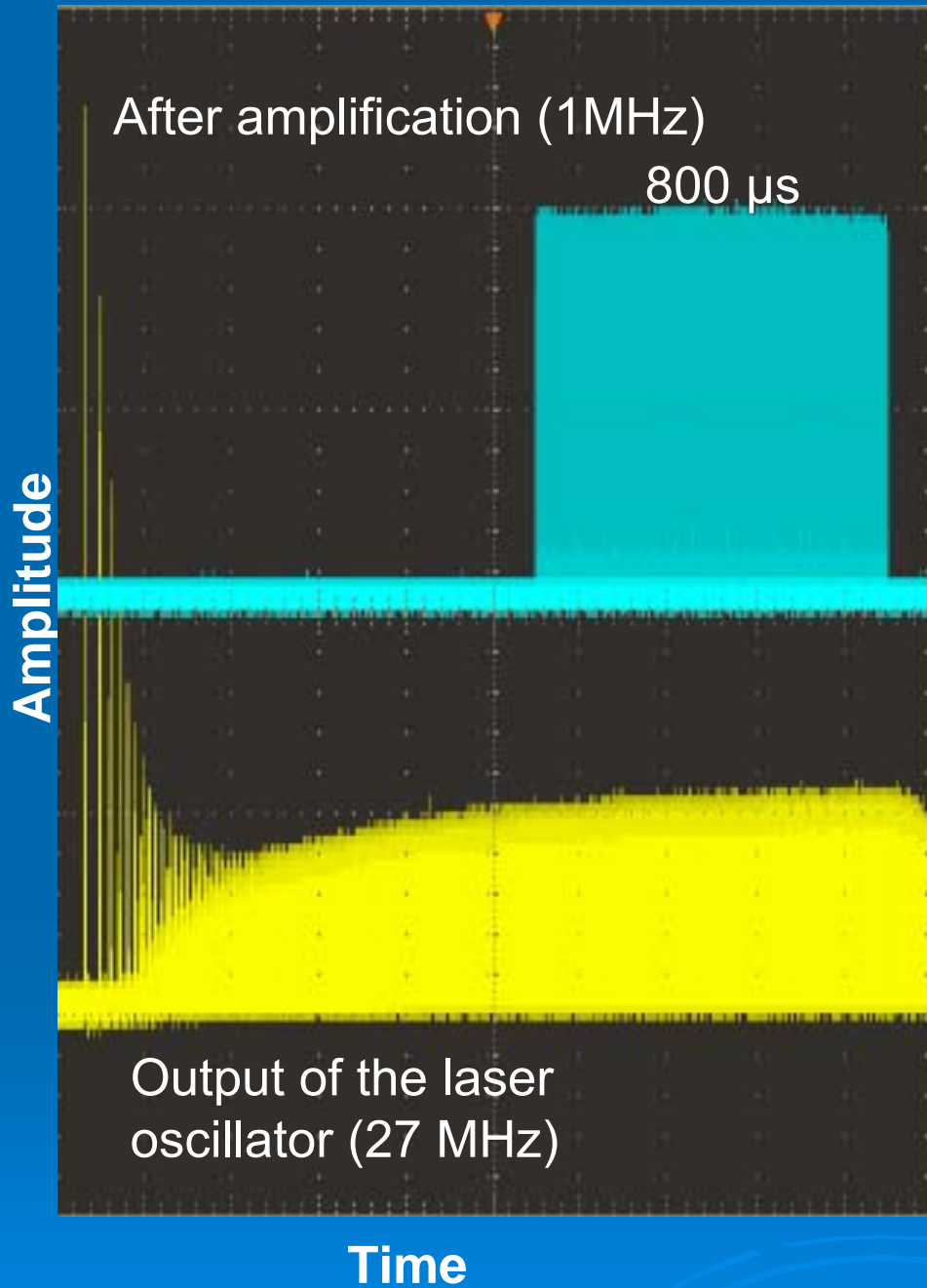

Courtesy: Siegfried Schreiber, DESY * XFEL Beam Dynamics 27-Feb-2006, DESY

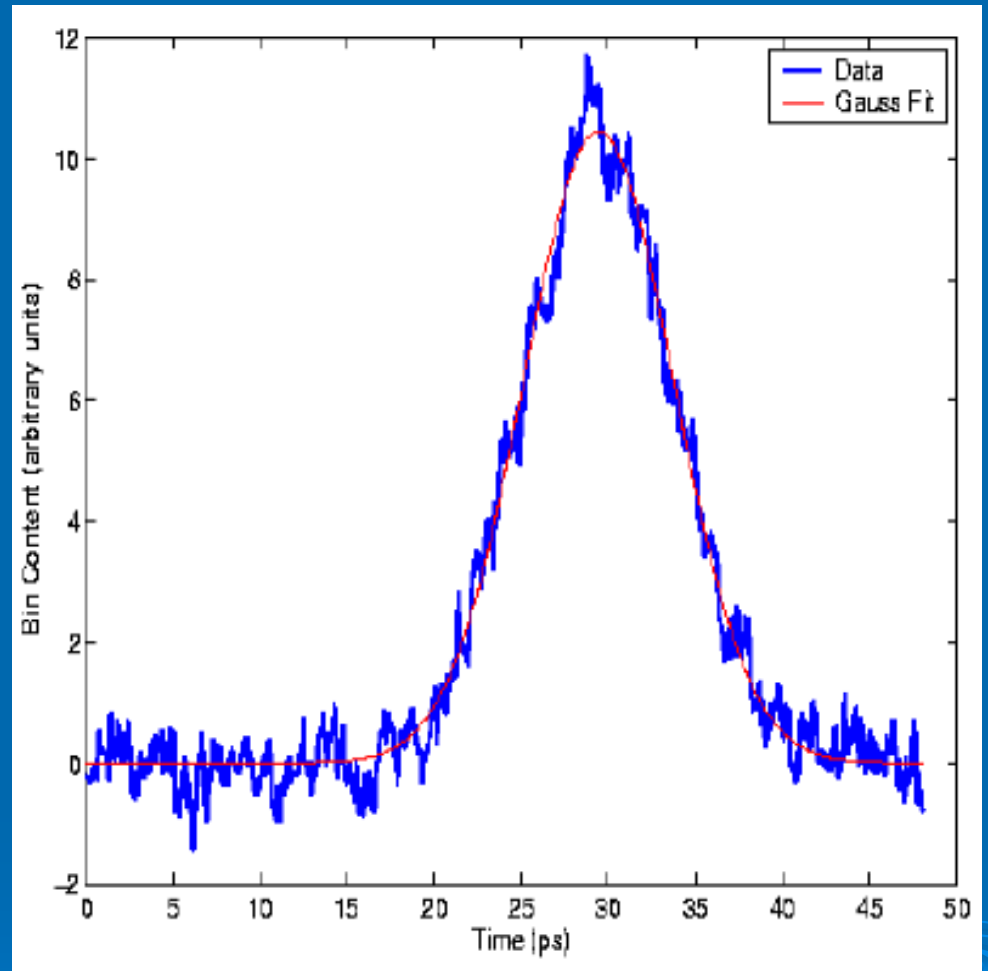
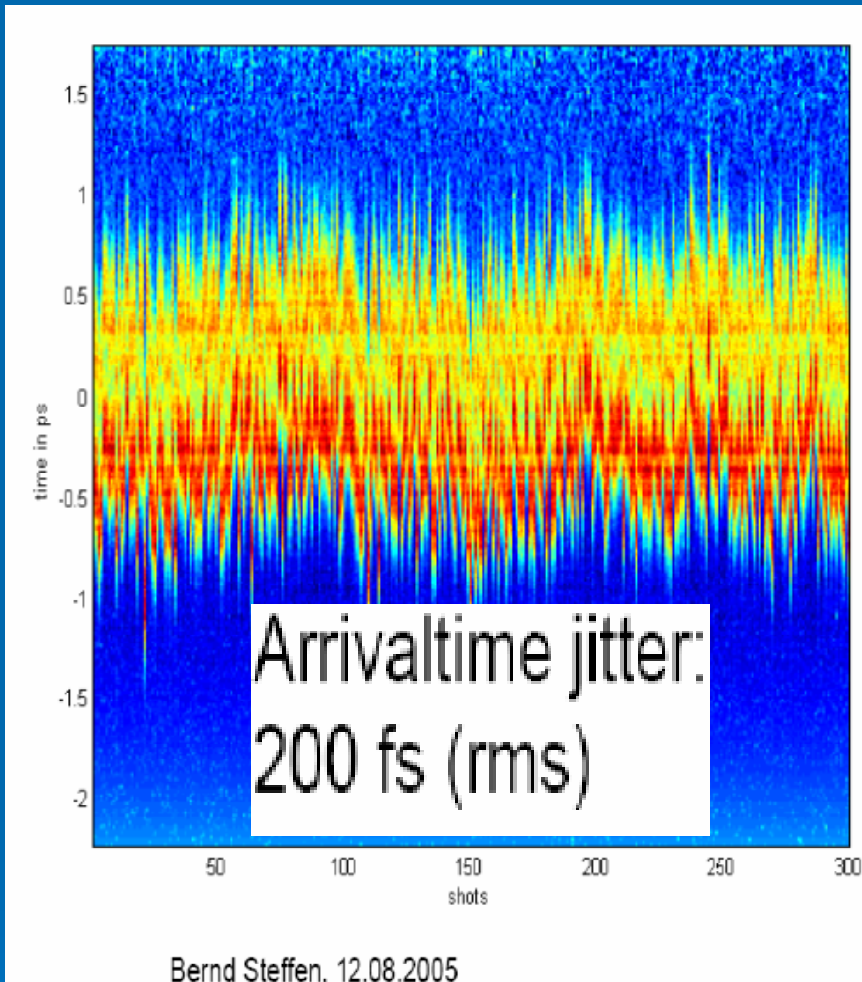

Longitudinal shape is Gaussian
Average over 50 gives
 $\sigma_L = 4.4 \pm 0.1$ ps (at 262 nm)

Advantages:

- ✓ Relatively high QE
- ✓ Relatively easy preparation
- ✓ Relatively long Life time
- ✓ Workable Load-lock

Disadvantages:

- Sensitive to vacuum contamination
- Preparation
- Life time
- UV wavelength

Laser System for K_2CsSb Cathode and GaAs:Cs Cathode for unpolarized electrons

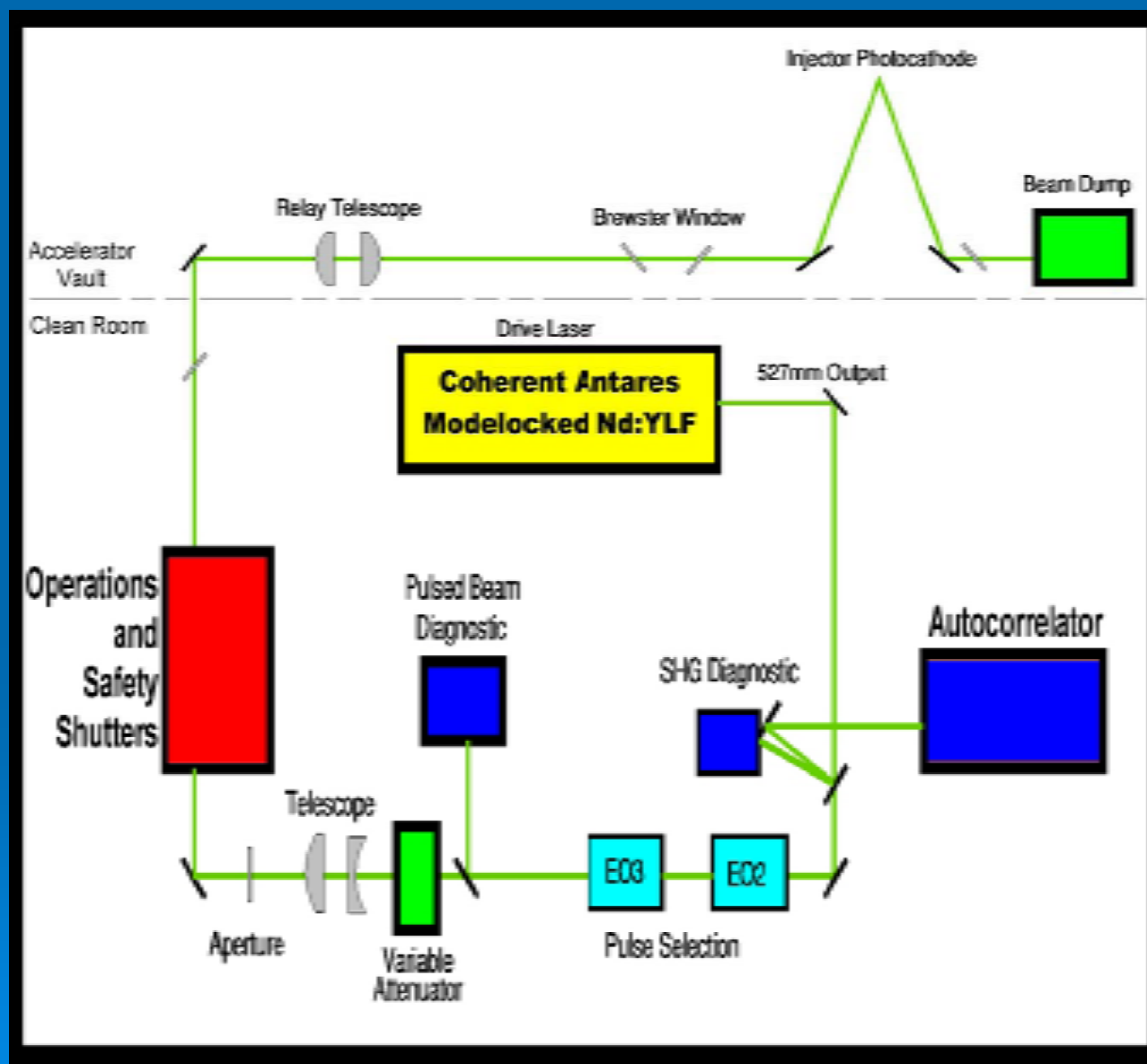

Courtesy:

http://www.jlab.org/intralab/calendar/archive04/erl/talks/WG1/WG1_Shinn_Tue_0830.pdf

Parameter Specification For upgrade

IR output wavelength:	1064 nm
IR output Power	~ 70 W
SHG output wavelength	532 nm
SHG output power	≥ 25 W
SHG amplitude stability	$\leq \pm 0.5$ %
Timing stability	≤ 1 ps
Beam quality	Better than 3x diffraction-ltd
Pointing stability	< 20 μ rad
Beam profile	Circular (up to 25% ellipticity OK

Laser system for K2CsSb Cathode At Boeing

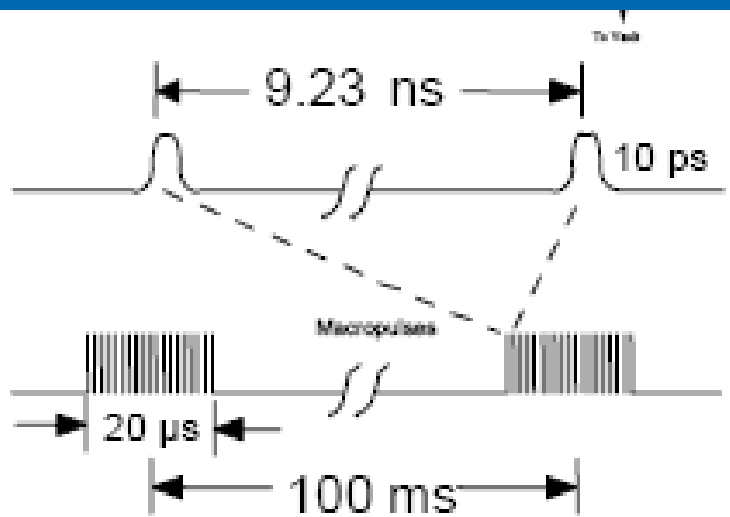
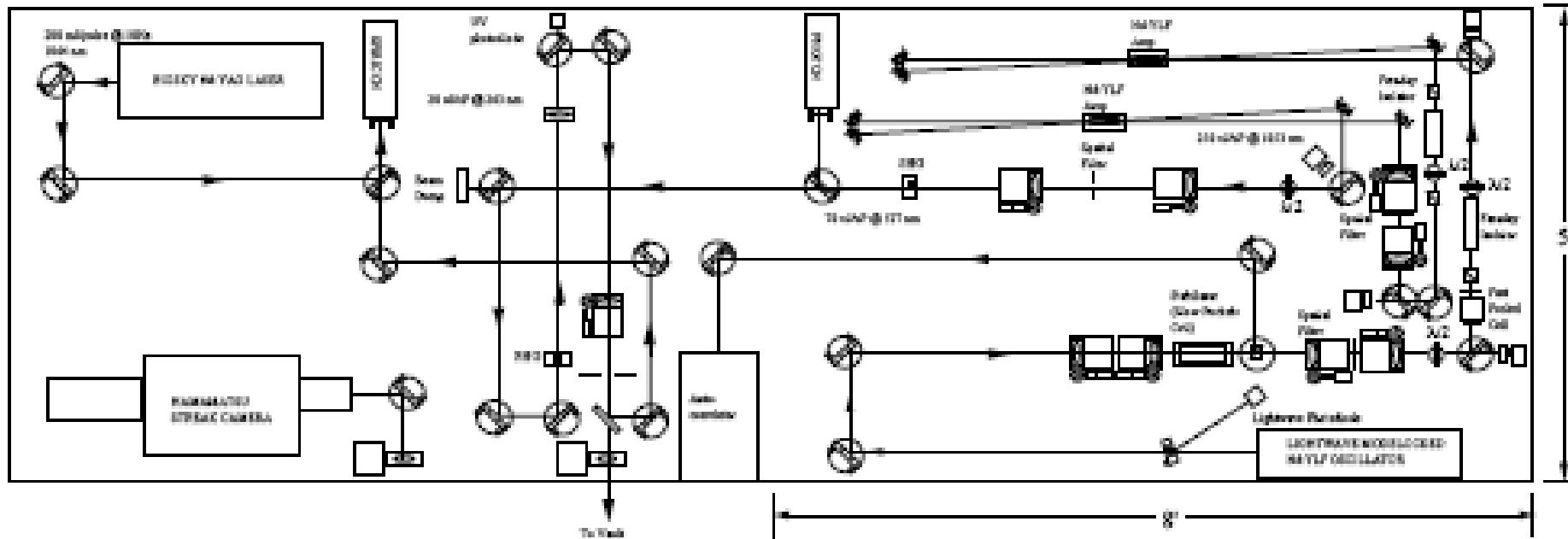

Drive Laser Characteristics

@1053 nm = 30 μ J

@527 nm = 15 μ J

@263 nm = 5 μ J (1 nC at 0.1%)

Macropulse = 2000 Micropulses

Macropulse Rep. Rate = 10 Hz

Diode-pumping to increase duty factor.

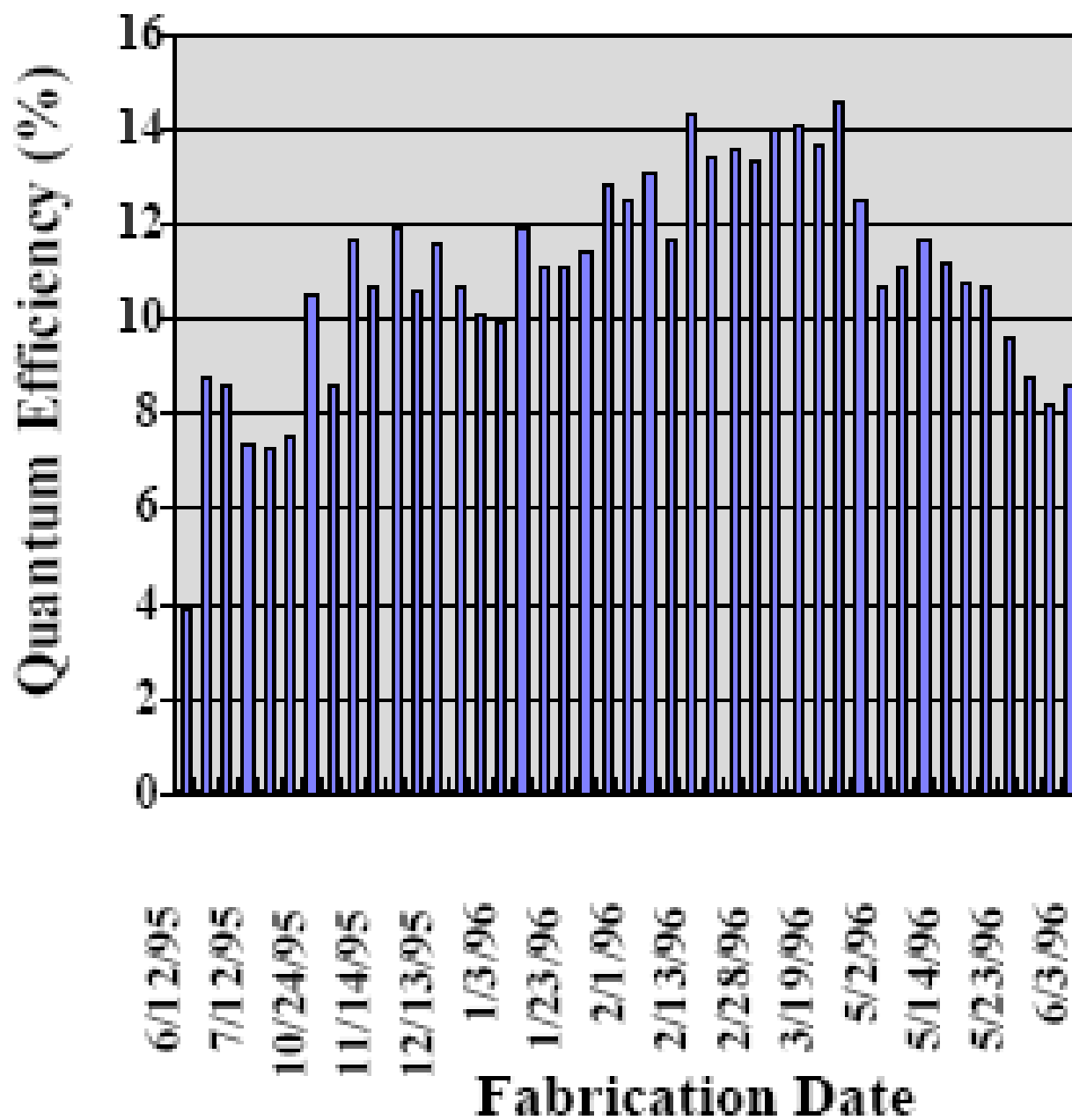

K_2CsSb cathode

Advantages:

- ✓ High QE
- ✓ Visible wavelength
 - ✓ Laser system is feasible for high current
- ✓ Tested in RT RF injector

Disadvantages:

- Sensitive to vacuum contamination
- Complicated preparation
- Load Lock needed

GaAs: Cs unpolarized e⁻

Advantages:

- ✓ High QE
- ✓ Visible wavelength
 - ✓ Laser system is feasible for high current
- ✓ Tested in RT DC injector
- ✓ Low thermal emittance: NEA surface

Disadvantages:

- Delayed emission
- Extremely sensitive to vacuum contamination
- Sensitive to Ion bombardment
- Charge limited life time

Fiber Laser System for GaAs:Cs Polarized Electrons

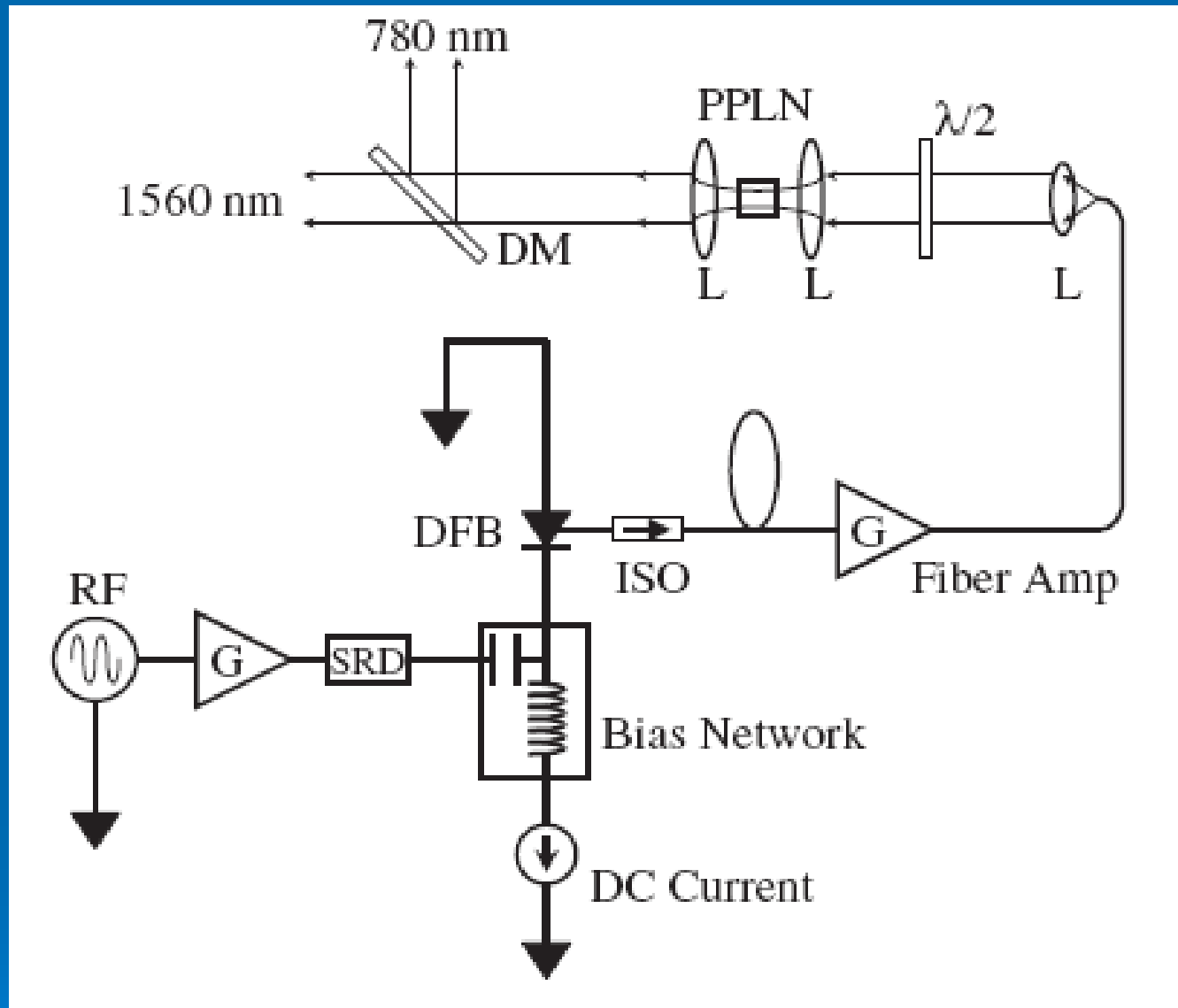

Schematic of the fiber-based laser system. DFB, distributed feedback Bragg reflector diode laser; ISO, fiber isolator; SRD, step recovery diode; L, lens; PPLN, periodically poled lithium niobate frequency-doubling crystal; DM, dichroic mirror.

Courtesy: http://www.jlab.org/accel/inj_group/laser2001/e063501.pdf

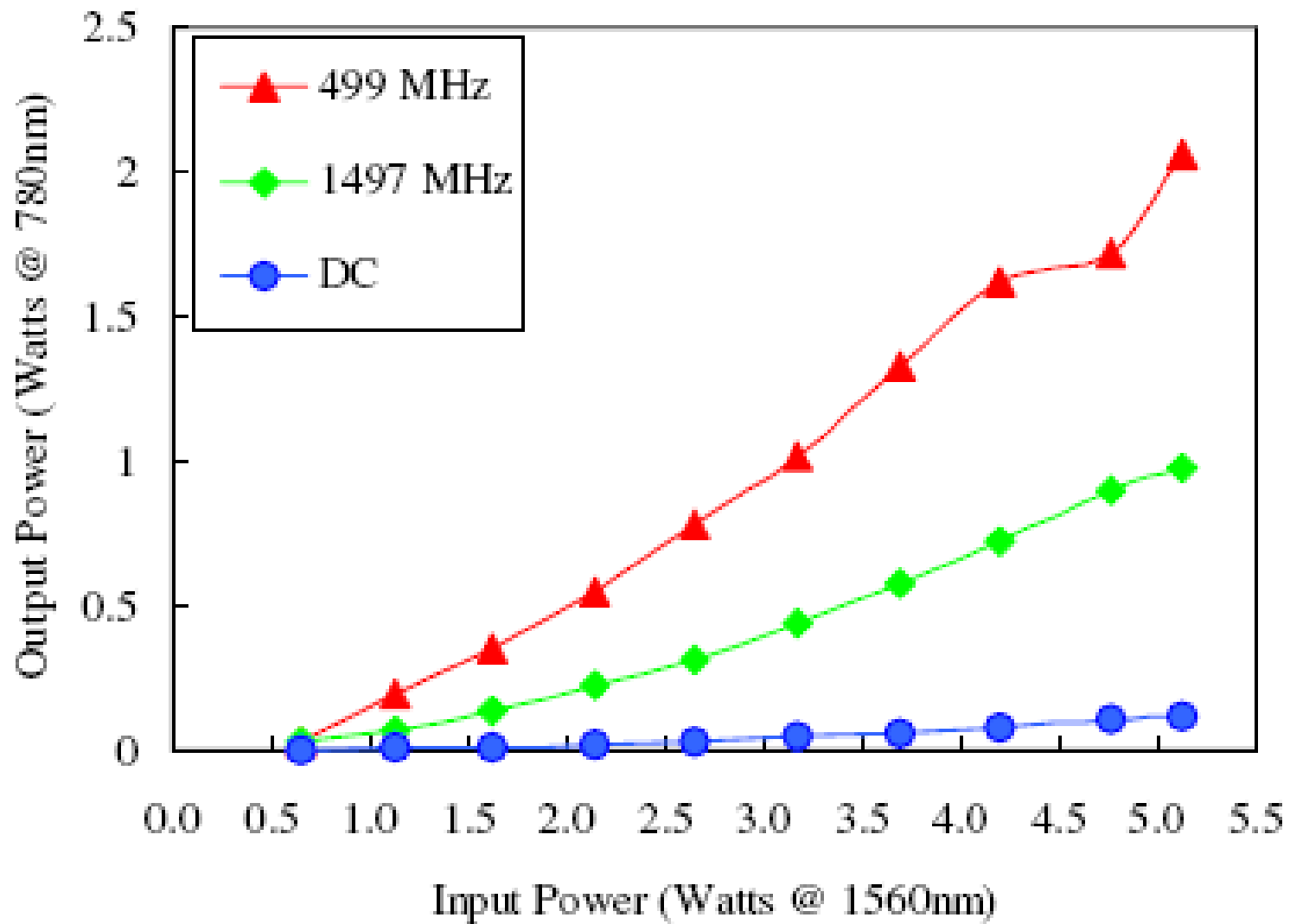

Output power of the fiber-based laser system at 780 nm versus input power from the seeded ErYb-doped fiber amplifier at 1560 nm. Three different seed conditions were tested; DC and rf-pulsed input at 499 and 1497 MHz

Maintaining Spatial Profile

ATF Gun Hutch Laser Optics

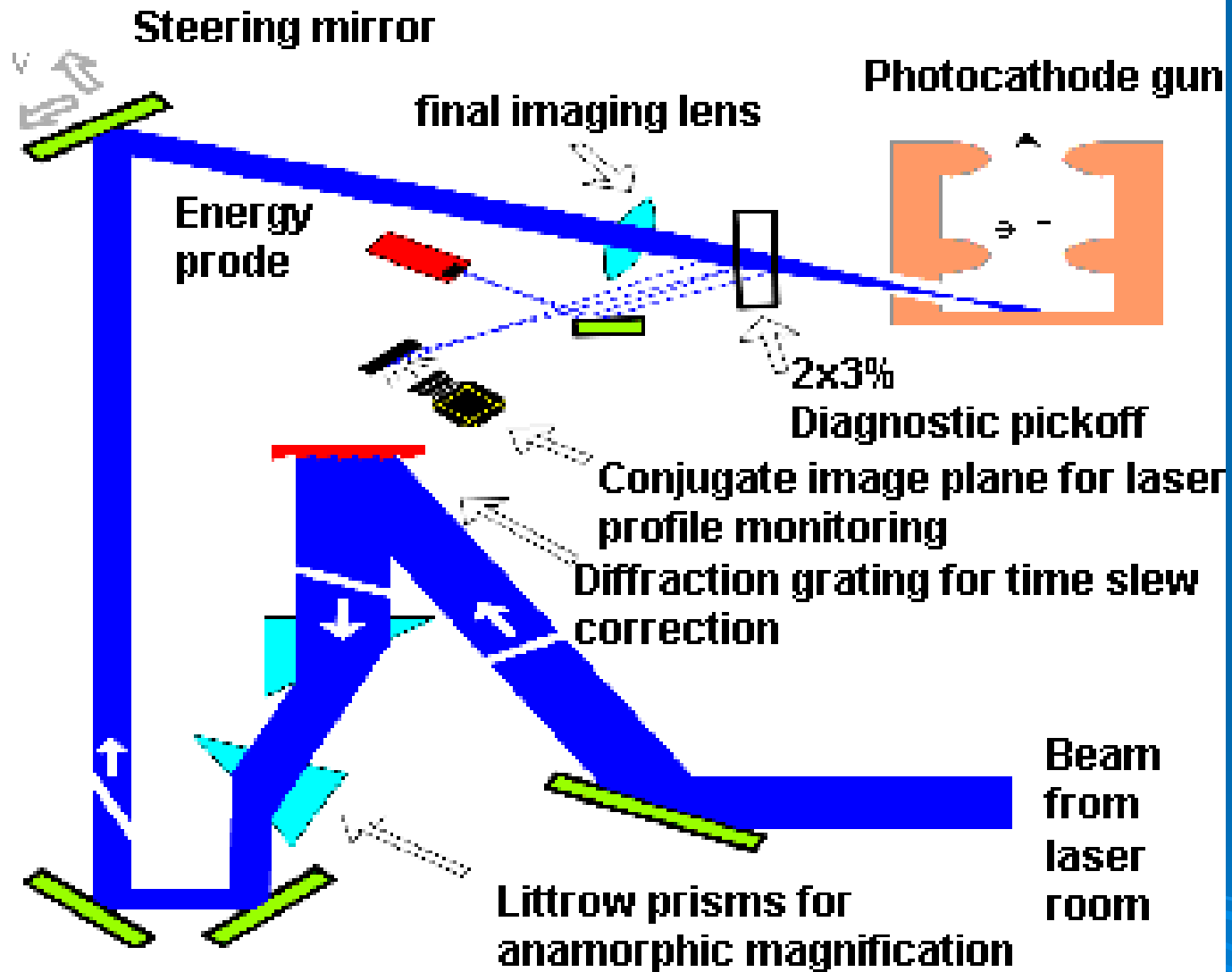

Courtesy:

http://www.bnl.gov/atf/core_capabilities/gun_hutch.asp

Timing Synchronization critical for all Laser applications:

➤ Electron generation

- Reduce emittance
- Reduce energy spread
- Reduce loss in e Beam transport

➤ Electron-Laser Interaction

- Maintain Phase relationship between e & laser
- Optimize interaction-overlap time

➤ Electron diagnostics

- Improve resolution
- Increase signal/noise

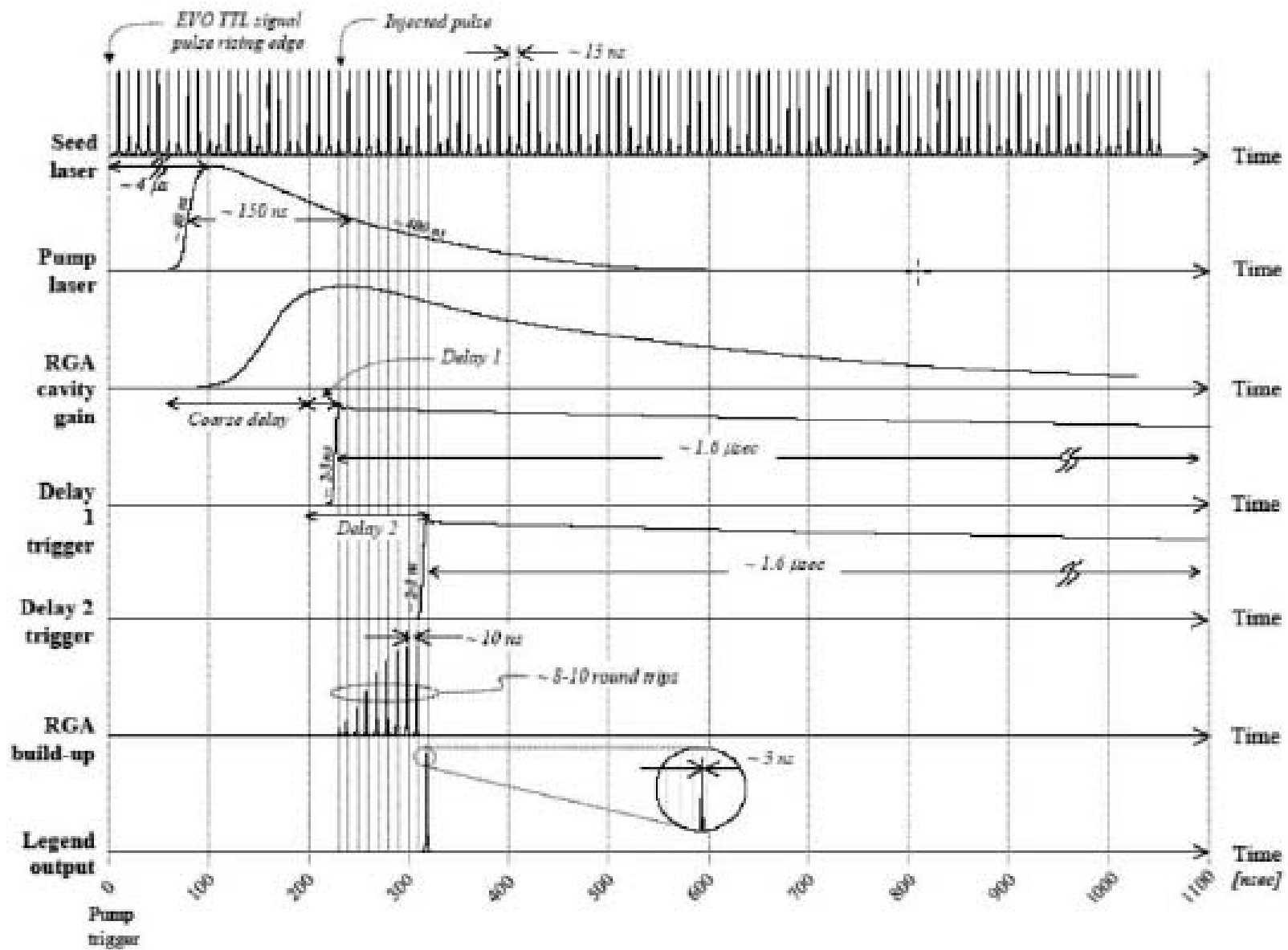

Timing diagram of the laser system

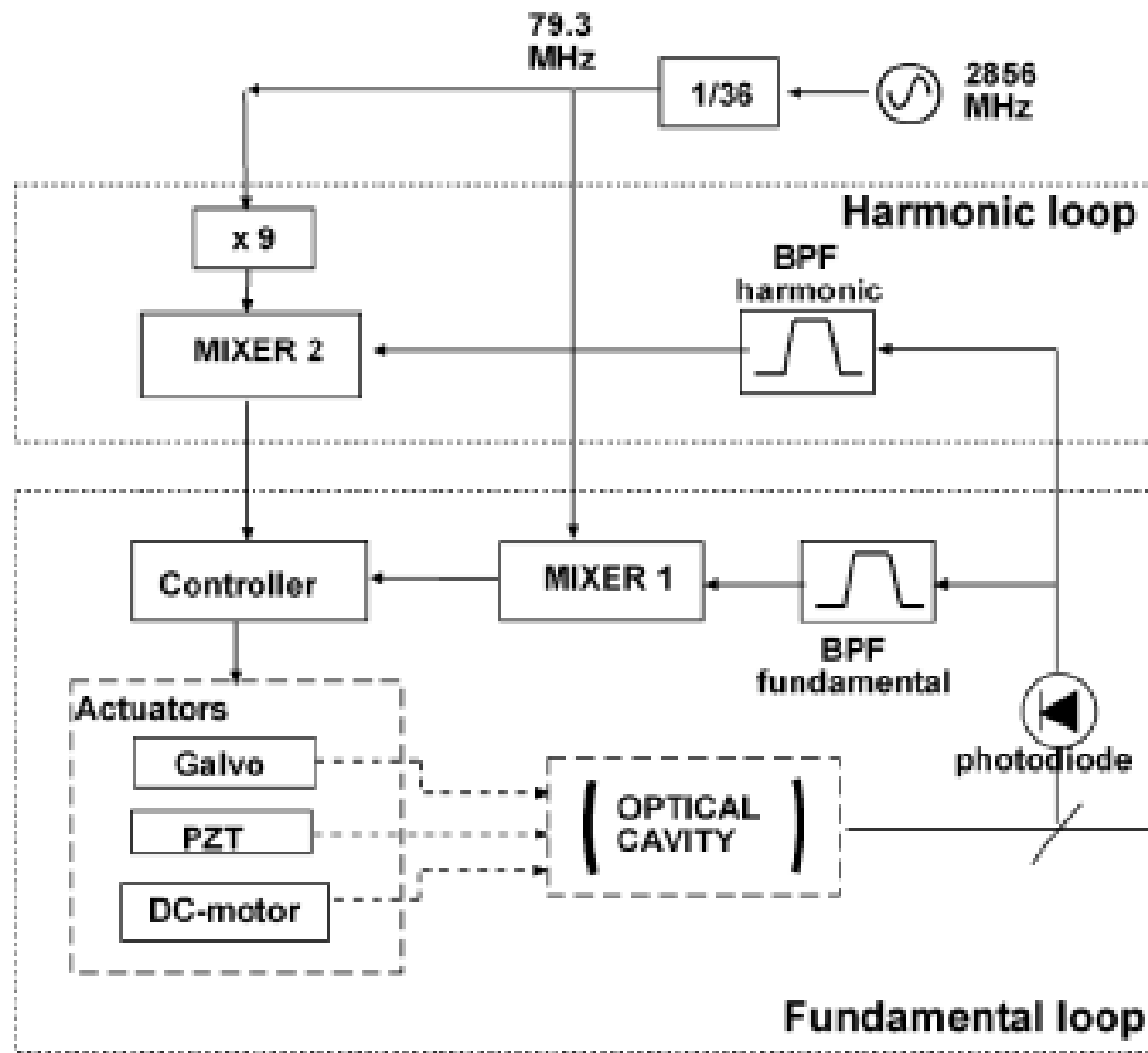

Courtesy: EUROFEL-Report-2006-DS3-027: SPARC photo-injector synchronization system and time jitter measurements, M. Bellaveglia, A. Gallo, C. Vicario

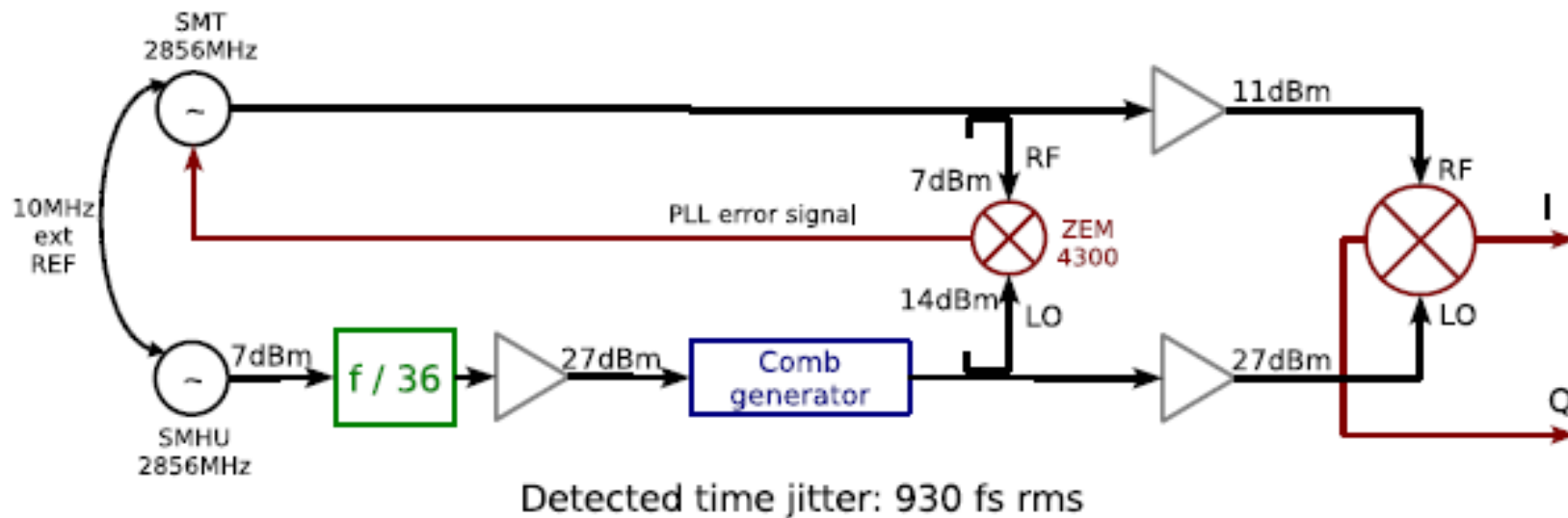
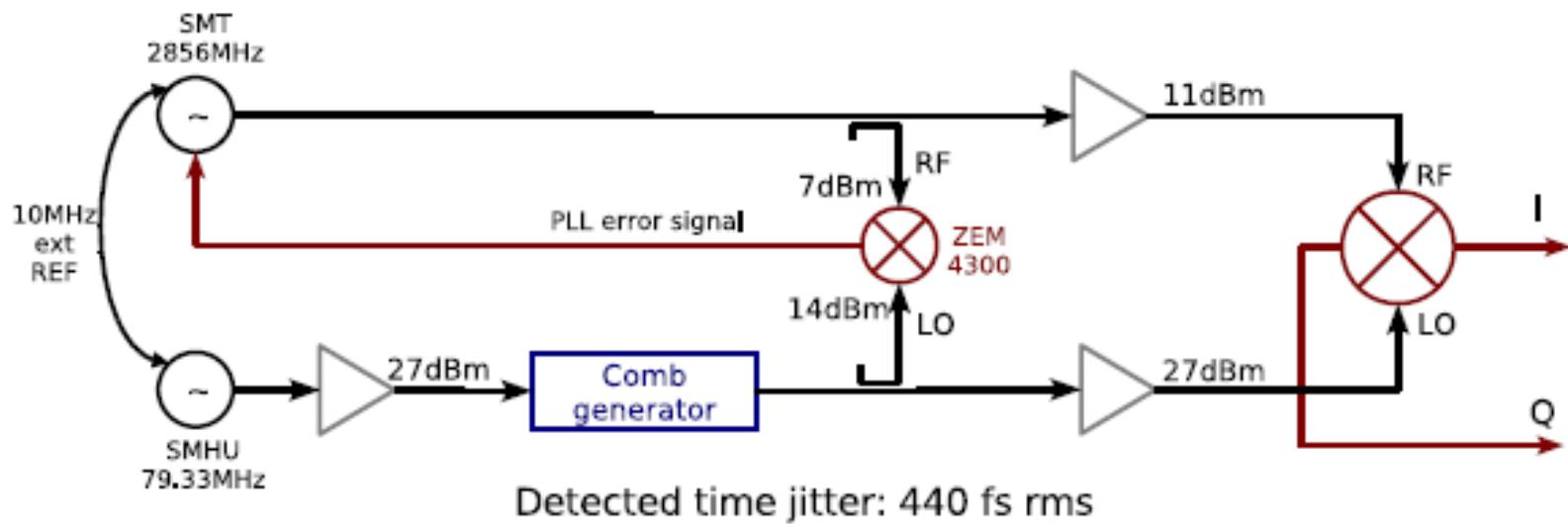

Measurement setup and results for the home-designed electronic frequency divider card (PLL BW = 5kHz)

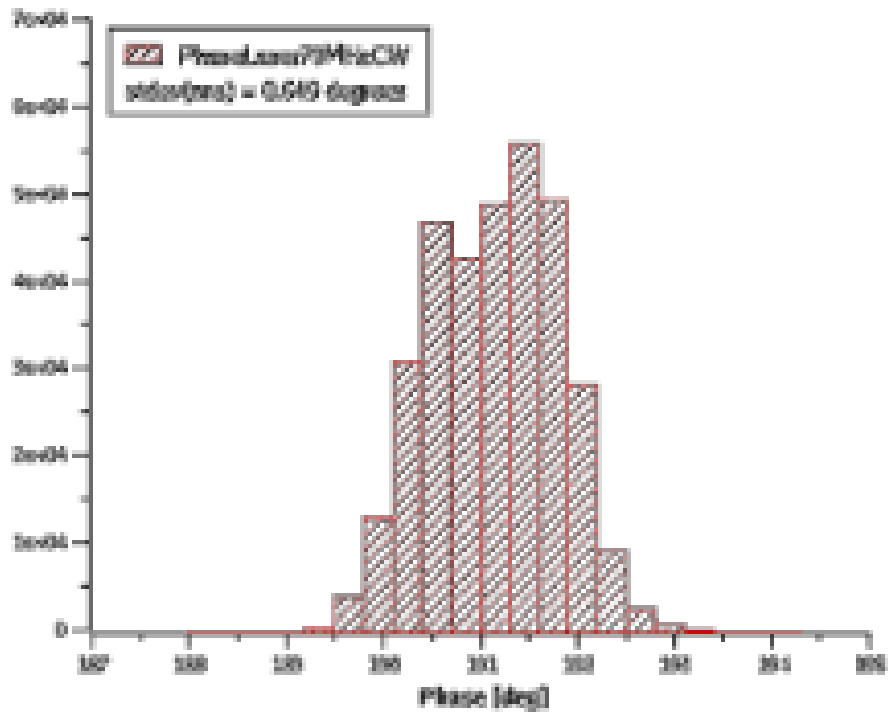

(a)

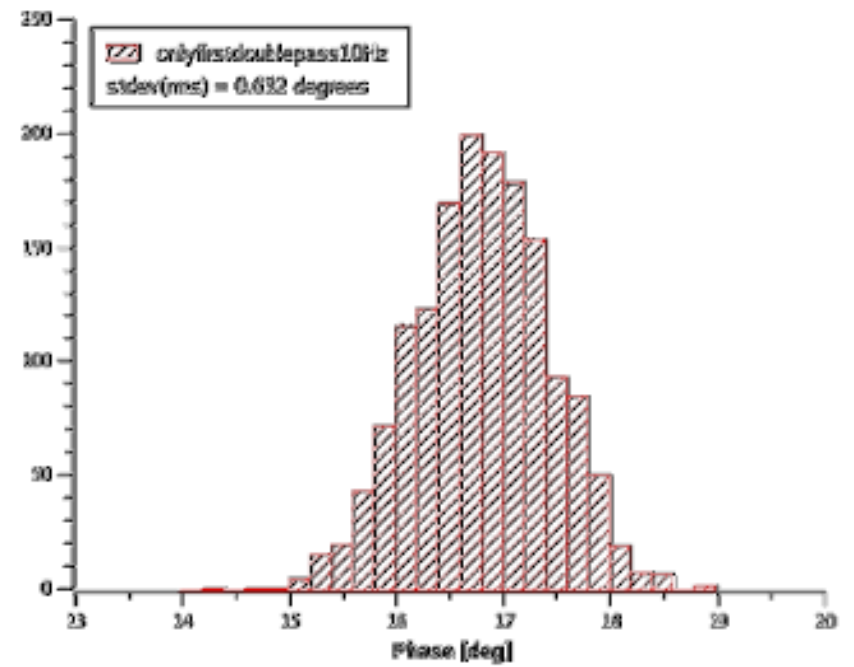

(b)

Histograms relative to (a) 79MHz IR and (b) 10Hz UV phase noise measurements

Typical Synchronization Scheme: Phase lock loop

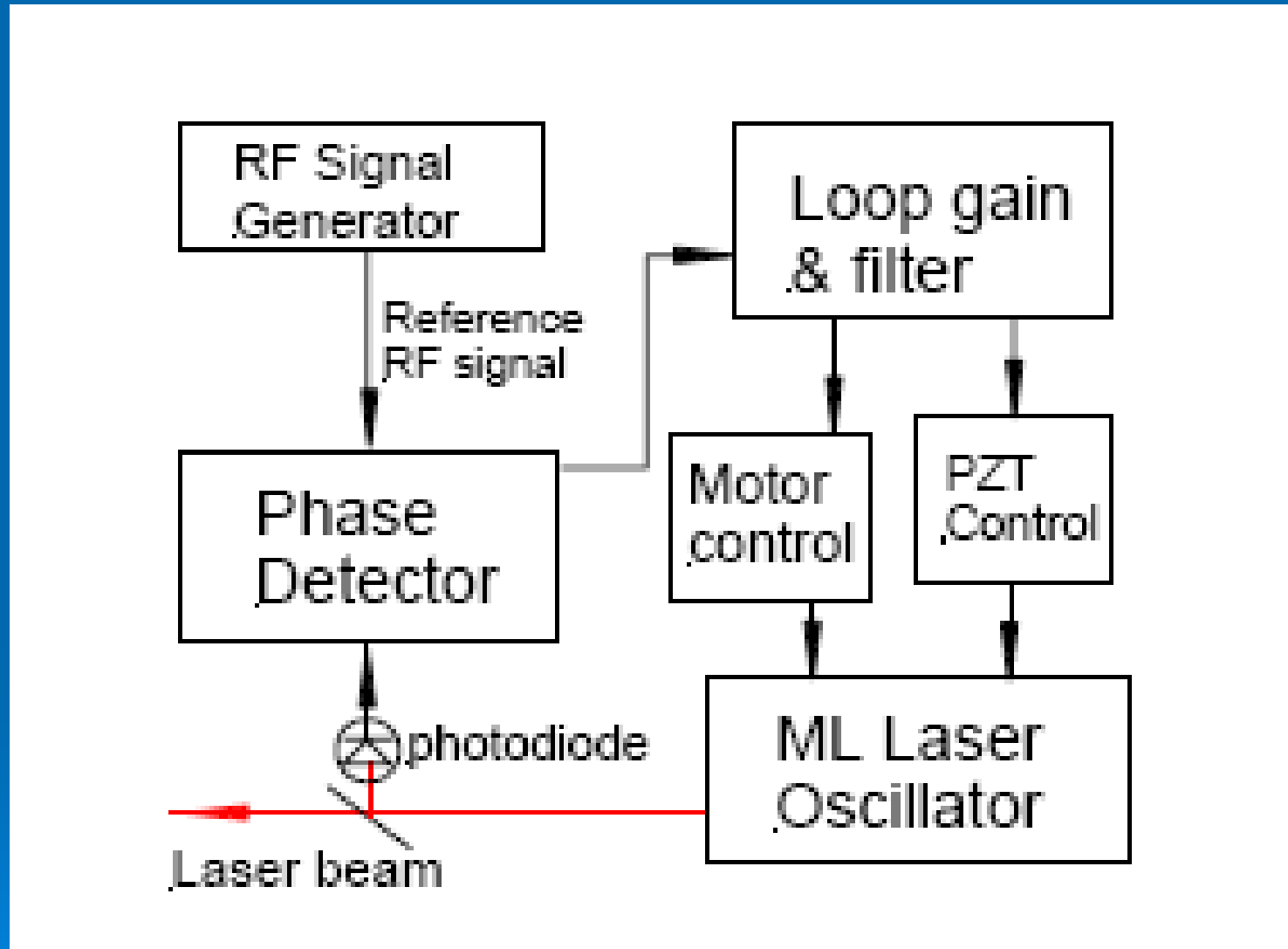

Courtesy:

Proceedings of FEL 2006, BESSY, Berlin, Germany

S. Zhang, S. Benson, J. Hansknecht, D. Hardy, G. Neil, and M. Shinn

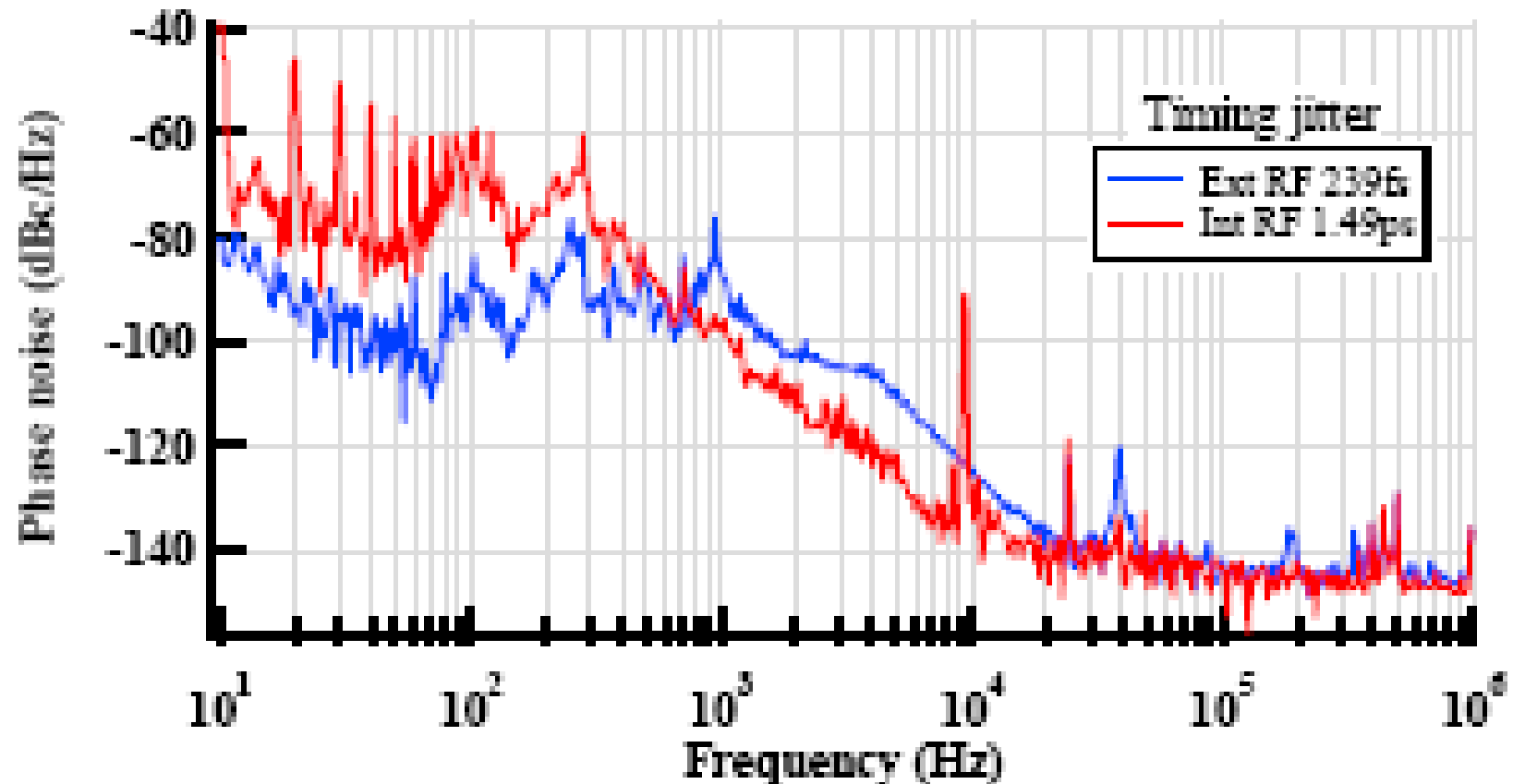

(a)

Phase noise of a Laser with stable cavity length and AOM to control the phase

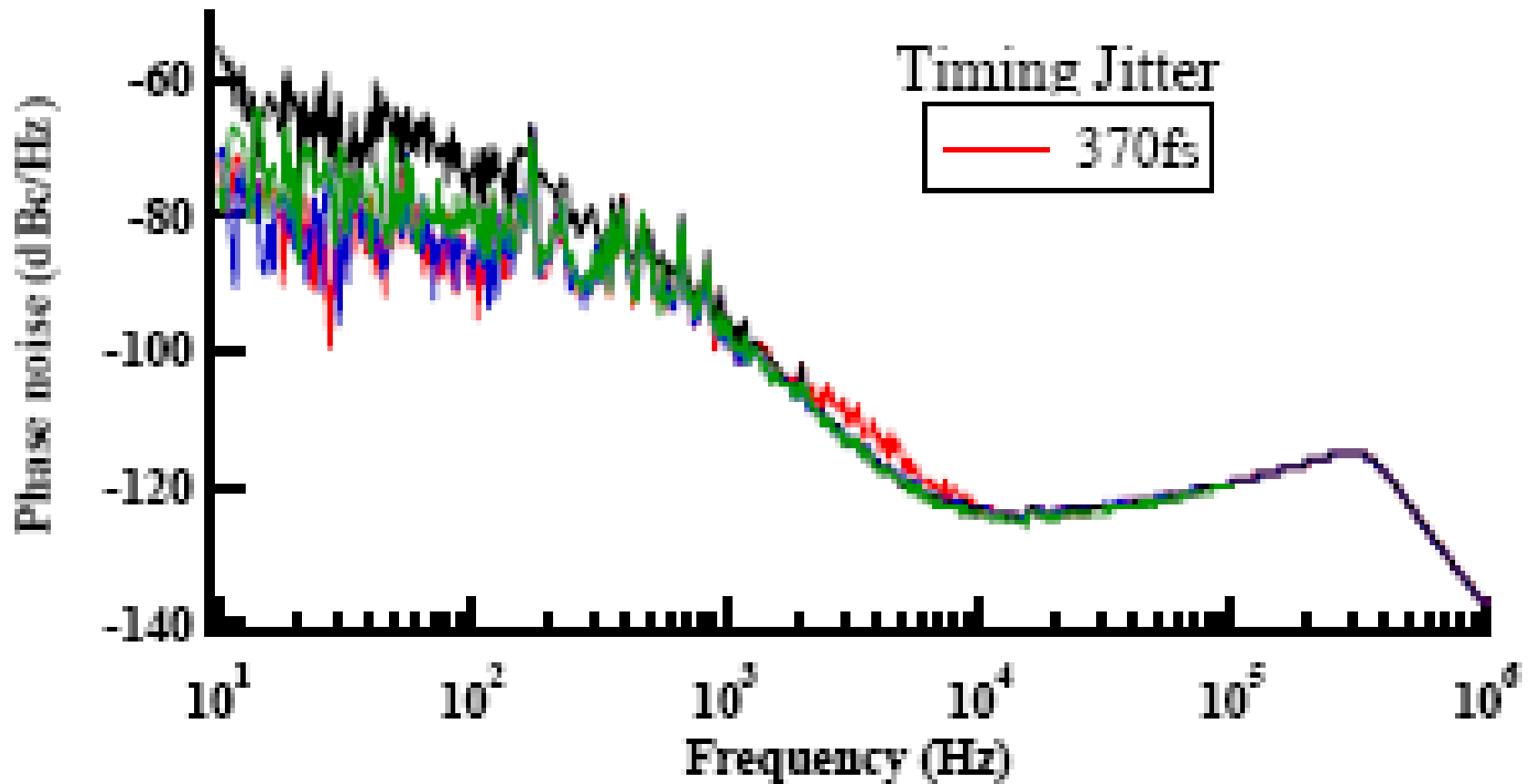

Phase noise of laser w/ Semiconductor saturable absorber mirror (SESAM) for mode locking and active cavity length control for phase locking

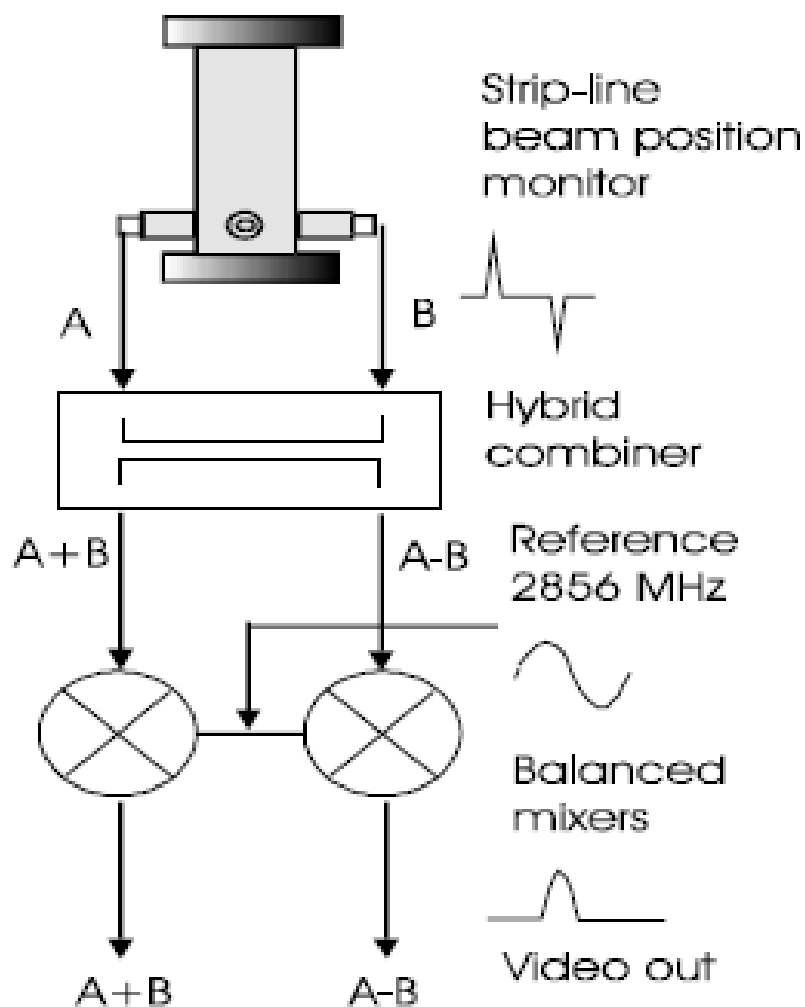

Figure 1. The stripline beam position monitor system.

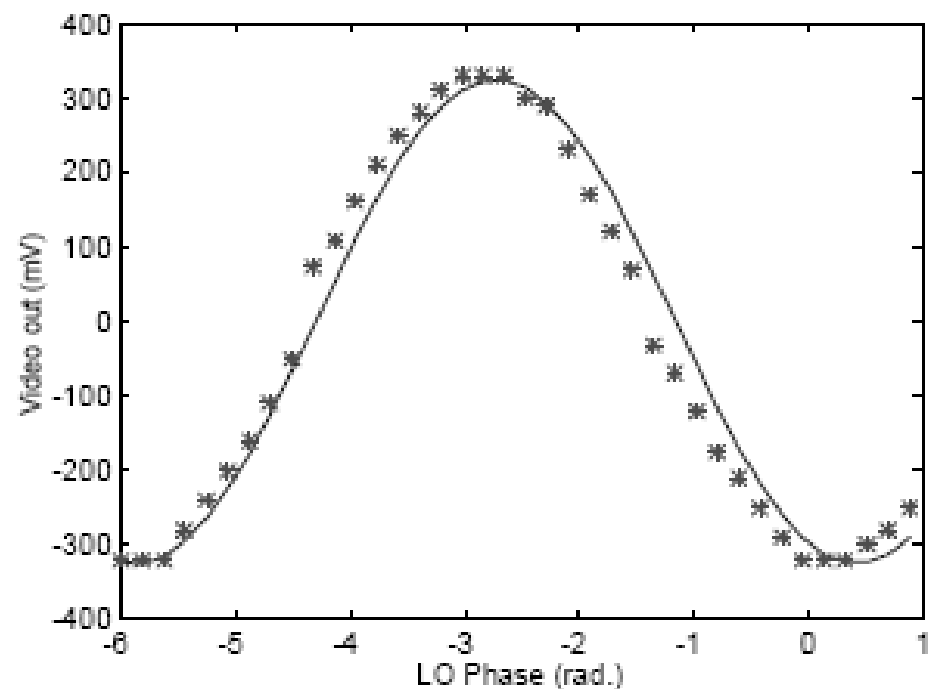
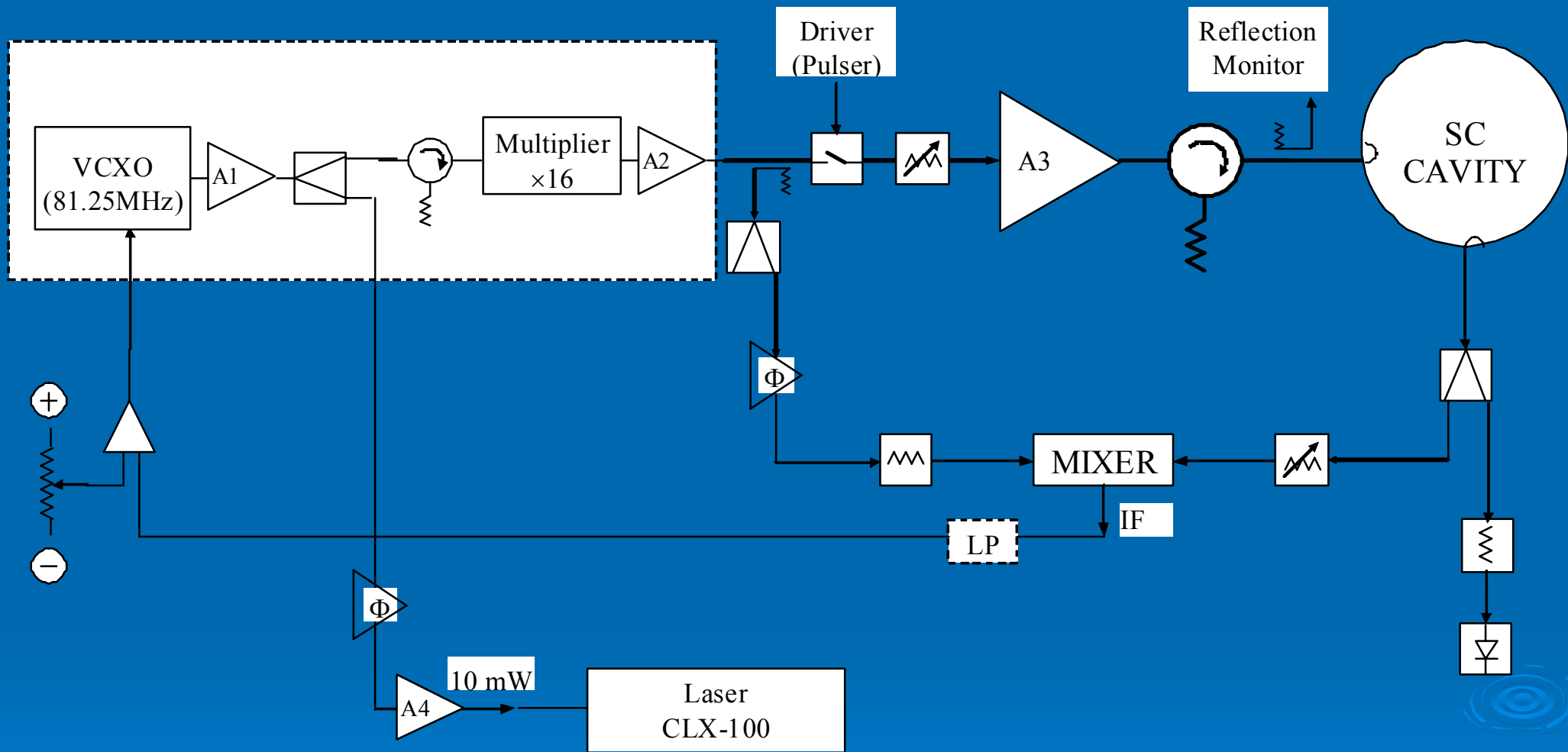

Figure 5. Stripline BPM sum video out vs. Local oscillator phase.

The sensitivity of our system was measured to be 6.5mV/ps. Using this technique, we have measured the rms timing jitter between the laser and RF system is 0.5 ± 0.25 ps.

Synchronizing Self Excited Cavity



Synchronizing two lasers and RF cavity

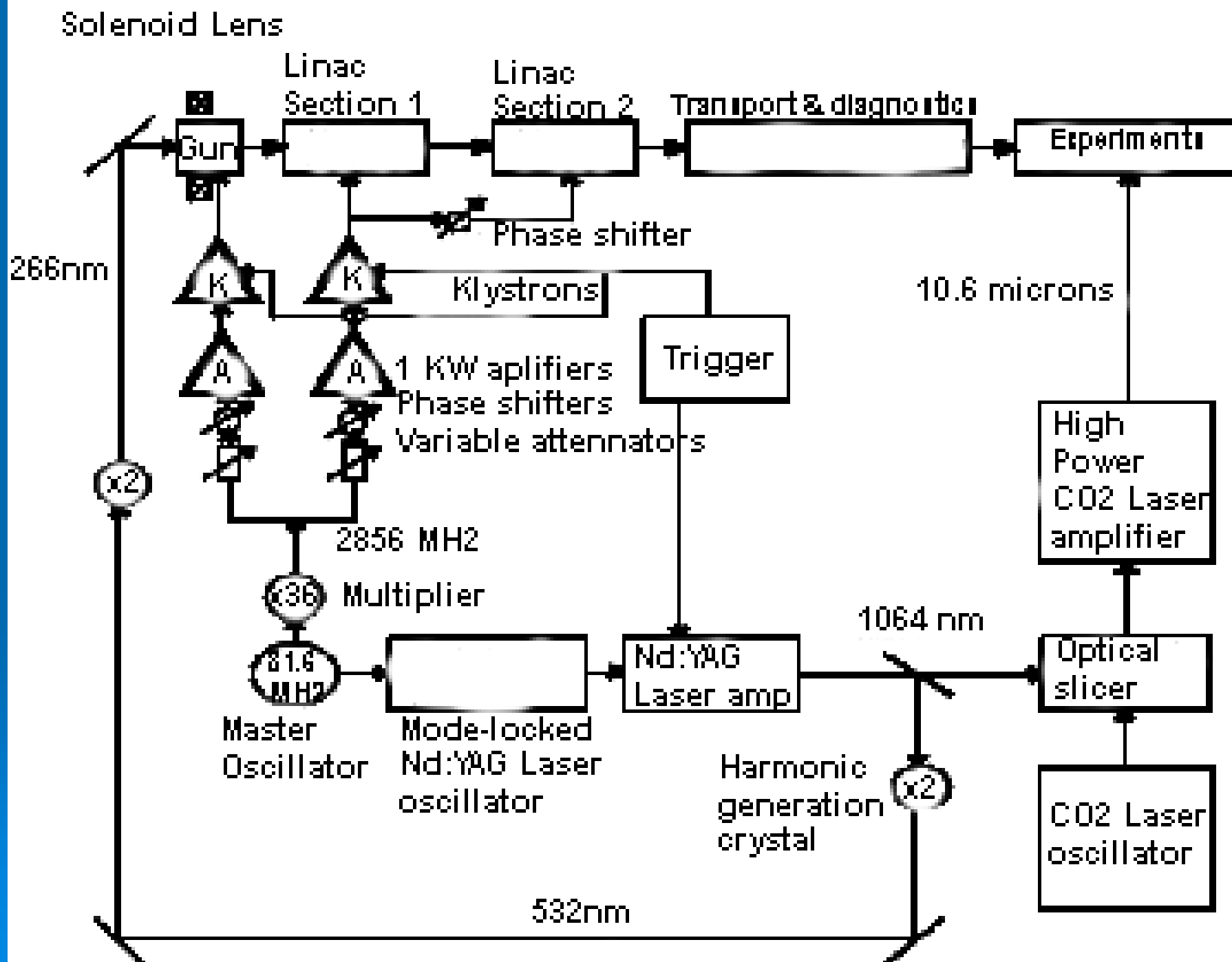

Maintaining Control of phase in transport

- Control laser path length
 - Temperature and temperature gradient
 - Air current
 - Humidity

Vacuum transport

- Adjustable delay line



Amplitude Stability:

✓ Commercial oscillator stability acceptable

o Amplifier stability

- Compromise between gain and stability
- Gain-higher energy, lower stages but higher fluctuation
- Stability-saturation-higher stability but lower gain, more stages, beam shape

o Harmonic conversion

- High conversion efficiency Vs stability
 - Impact on beam profile-spatial and temporal