

Vacuum Science and Technology for Accelerator Vacuum Systems

*Yulin Li and Xianghong Liu
Cornell University, Ithaca, NY*

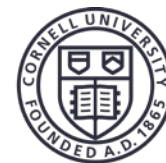

Cornell Laboratory
for Accelerator-based Sciences
and Education (CLASSE)

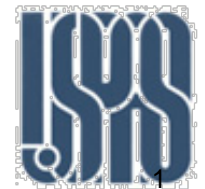

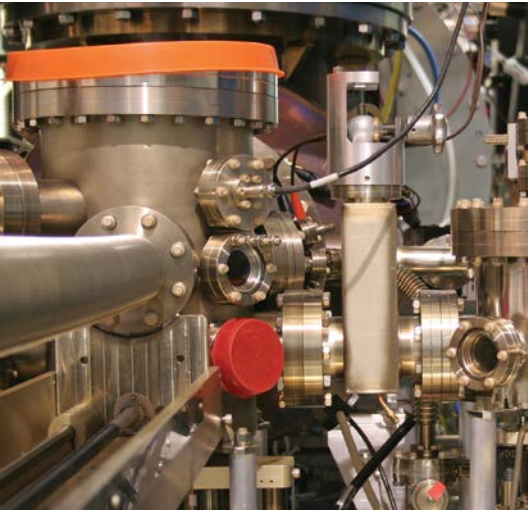

Table of Contents

- Vacuum Fundamentals
- Sources of Gases
- Vacuum Instrumentation
- Vacuum Pumps
- Vacuum Components/Hardware
- **Vacuum Systems Engineering**
- Accelerator Vacuum Considerations, etc.

SESSION 6.2: Vacuum System Integrations

- ❑ *Vacuum construction and quality control*
- ❑ *Mechanical considerations*
- ❑ *Leak checking*
- ❑ *Bakeout*
- ❑ *Installation and commission*
- ❑ *Vacuum controls and interlocks*
- ❑ *Vacuum performance monitoring*

Vacuum Components

Construction and quality control



- *Appropriate design review and approval procedure is the first step in vacuum component quality control. For high performance accelerator vacuum chambers, at least the following aspects must be reviewed by internal/external experts.*
 - *Compatible material and joint techniques*
 - *Sufficient vacuum pumping for handling calculated gas-loads and instrumentation*
 - *Acceptable beam apertures for all operational conditions*
 - *Expected beam induced heating power (SR, etc.) and adequate cooling*
 - *Higher-order-mode power loss and beam impedance evaluation*
 - *Installation procedures - fit in allowed spaces, easiness in installation, required tooling and fixtures, support and survey, etc.*

Vacuum construction and quality control Cont.



DETAIL A
SCALE 2:1

15	6046-036-04	Aluminum SST Cup
14	6046-036-03	Sliding Joint MKII Flange 'E'
13	SHEET 7	Assembly

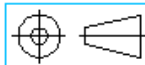

ITEM	DWG. NO.	DESCRIPTION

RELEVANT APPROVALS REQUIRED BEFORE FABRICATION.			
VACUUM PROPERTIES:	OK	DATE	N/A
SYNCH. RAD. POWER:	YL	3/02/02	
H.O.M. HEATING:	DHR	3/17/02	
APERTURE CHECKOUT:	MGB	3/08/02	
INSTALLATION PROCEDURE:	DLR	3/09/02	
	YL	3/02/02	
FOR MACHINING LUBRICANT USE ONLY ALKALINE DETERGENT LUBRICANT CIMSTAR 40 OR EQUIVALENT APPROVED BY CORNELL LNS.			

PRINT DISTR.	CR-1
PLOT DATE	5/7/02
CAD FILE NAME	ASM-6070-036-FEMALE
UNLESS OTHERWISE SPECIFIED	
DIMENSIONS ARE IN INCHES	
TOLERANCES ON:	
.00 ±.010	
.000 ±.005	
FRACTIONS ±1/64	
ANGLES ±0.5°	
ALL SURFACES	✓
CHECKED BY	Yulin Li
DRAWN BY	Yulin Li
DRAWN FOR	Yulin Li
DATE	4/11/02
APPROVED BY	Yulin Li

Cornell Univ
Floyd R. Newman Laborat
CESR-C WIGGLER, MAS
FEMALE ASSEMBLY (MA

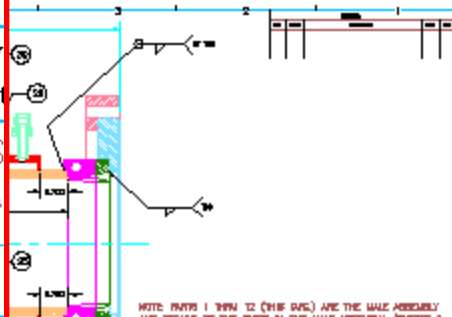

NOTE: PARTS 1 THRU 12 (THIS SHEET) ARE THE MALE ASSEMBLY AND DETAILS OF THE PARTS IN THE MALE ASSEMBLY. (SHEETS 1 THRU 12)

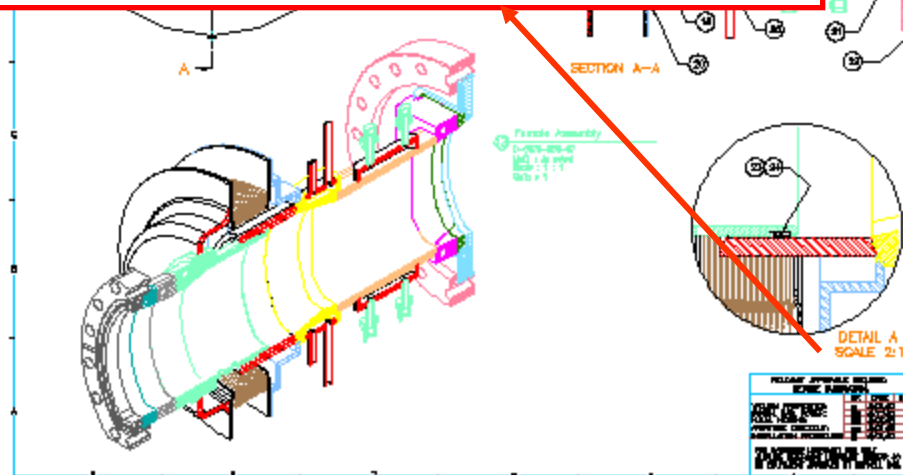

33	Part 10	1/2" Diameter, milled
34	SHEET 18	Part 11
35	SHEET 7	Part 12
36	SHEET 7	Part 13
37	SHEET 7	Part 14
38	SHEET 18	Part 15
39	SHEET 18	Part 16
40	SHEET 18	Part 17
41	SHEET 18	Part 18
42	SHEET 18	Part 19
43	SHEET 18	Part 20
44	SHEET 18	Part 21
45	SHEET 18	Part 22
46	SHEET 18	Part 23
47	SHEET 18	Part 24
48	SHEET 18	Part 25
49	SHEET 18	Part 26
50	SHEET 18	Part 27
51	SHEET 18	Part 28
52	SHEET 18	Part 29
53	SHEET 18	Part 30
54	SHEET 18	Part 31
55	SHEET 18	Part 32
56	SHEET 18	Part 33
57	SHEET 18	Part 34
58	SHEET 18	Part 35
59	SHEET 18	Part 36
60	SHEET 18	Part 37
61	SHEET 18	Part 38
62	SHEET 18	Part 39
63	SHEET 18	Part 40
64	SHEET 18	Part 41
65	SHEET 18	Part 42
66	SHEET 18	Part 43
67	SHEET 18	Part 44
68	SHEET 18	Part 45
69	SHEET 18	Part 46
70	SHEET 18	Part 47
71	SHEET 18	Part 48
72	SHEET 18	Part 49
73	SHEET 18	Part 50
74	SHEET 18	Part 51
75	SHEET 18	Part 52
76	SHEET 18	Part 53
77	SHEET 18	Part 54
78	SHEET 18	Part 55
79	SHEET 18	Part 56
80	SHEET 18	Part 57
81	SHEET 18	Part 58
82	SHEET 18	Part 59
83	SHEET 18	Part 60
84	SHEET 18	Part 61
85	SHEET 18	Part 62
86	SHEET 18	Part 63
87	SHEET 18	Part 64
88	SHEET 18	Part 65
89	SHEET 18	Part 66
90	SHEET 18	Part 67
91	SHEET 18	Part 68
92	SHEET 18	Part 69
93	SHEET 18	Part 70
94	SHEET 18	Part 71
95	SHEET 18	Part 72
96	SHEET 18	Part 73
97	SHEET 18	Part 74
98	SHEET 18	Part 75
99	SHEET 18	Part 76
100	SHEET 18	Part 77
101	SHEET 18	Part 78
102	SHEET 18	Part 79
103	SHEET 18	Part 80
104	SHEET 18	Part 81
105	SHEET 18	Part 82
106	SHEET 18	Part 83
107	SHEET 18	Part 84
108	SHEET 18	Part 85
109	SHEET 18	Part 86
110	SHEET 18	Part 87
111	SHEET 18	Part 88
112	SHEET 18	Part 89
113	SHEET 18	Part 90
114	SHEET 18	Part 91
115	SHEET 18	Part 92
116	SHEET 18	Part 93
117	SHEET 18	Part 94
118	SHEET 18	Part 95
119	SHEET 18	Part 96
120	SHEET 18	Part 97
121	SHEET 18	Part 98
122	SHEET 18	Part 99
123	SHEET 18	Part 100





- ❑ *Detailed specifications of components are essential for UHV system construction.*
 - *Most vacuum chambers and components are complete or partially constructed by commercial companies and shops.*
 - *For simple chambers, standard industrial UHV-specifications and practices may be adapted with reviews*
 - *For complex (in construction or/and in operational conditions) chambers, detail specification must established to ensure the deliverables are in compliance with the designed performances, including machining fluid, cleaning method(s), joint techniques (welding, brazing, etc.), leak check rate, shipping and packing, etc.*
 - *Acceptance tests may also needed, including dimensional inspections, joint inspections, vacuum tests (leak check, bakeout, achievable vacuum level and residual gas analysis, etc.)*

Some Important Notes on Joint Designs



- ❑ *Non-demountable vacuum joints (welded, brazed, etc.) is commonly the weak spots in a vacuum system.*
- ❑ *All components must be UHV cleaned before any welding.*
- ❑ *For UHV systems, inside welds are usually preferred, to minimized potential trapped gas and contaminants. However, outside welds may be used in many situations, such as:*
 - *long seam joint w/ narrow gaps*
 - *welded joints that are very difficult to fix/patch (every welded joint may leak!)*
 - *inside welds that may results in large beads (aluminum welds, for example).*
 - *Inside welds and outside welds should NEVER 'meet'*
- ❑ *For long term reliability, water-to-vacuum joints are forbidden.*
- ❑ *Avoid high heating power deposition on the welded joints. The joints may be either shadowed by tapered recess, or by SR mask.*
- ❑ *Proper design of weld preps are essential in minimizing welding induced distortion. Making welded joints as symmetrical as possible is another way to avoid distortion.*

Auto-Welding System for Taiwan Photon Sources (TPS)

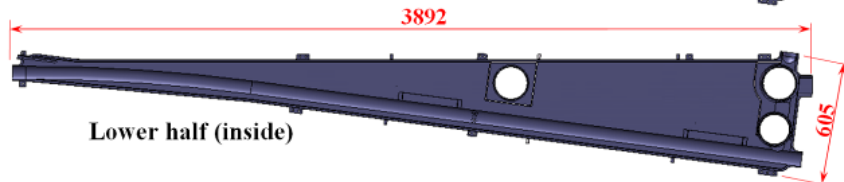
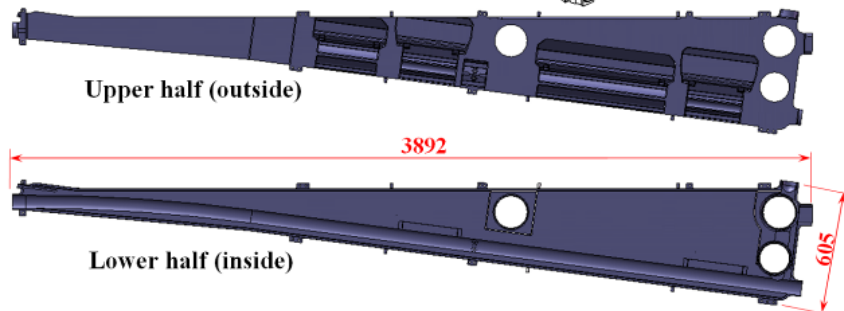
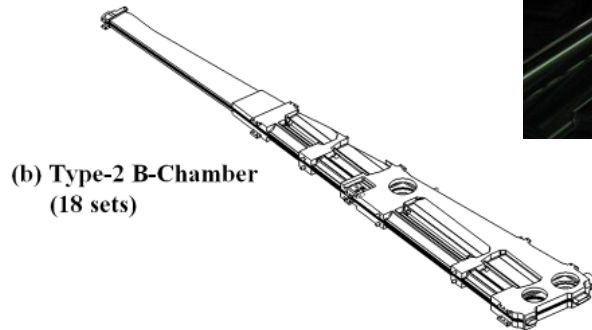
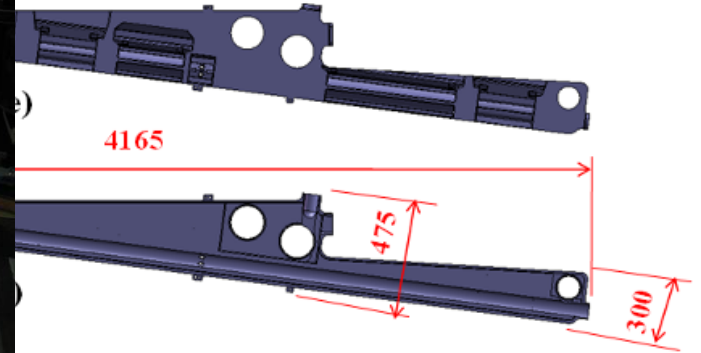
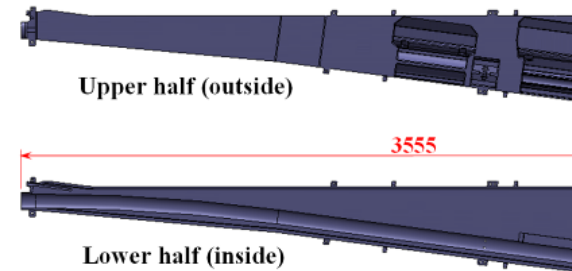
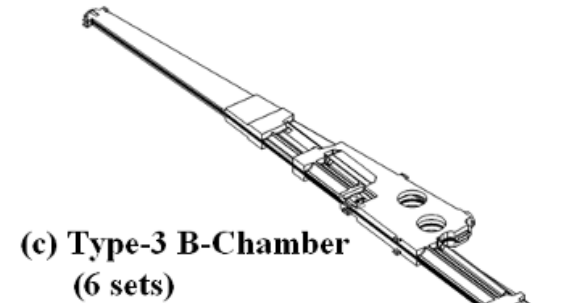
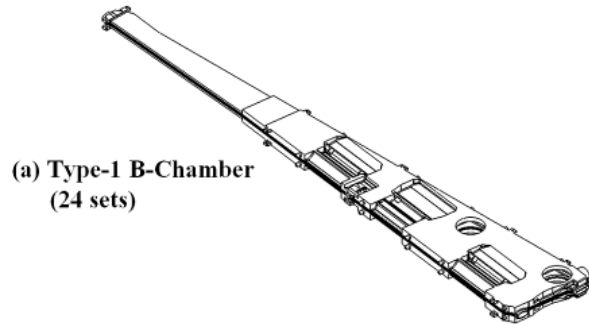

- This storage ring has 48 bending chambers.
- There are over 2700 weld seams for these TPS bending chambers.
- This involves a heavy work load if these 2700 weld seams are completed by hand.

Six-Torch Automatic Welding System

Advantages for automatic welding:

1. Longer welding distance— Fully coverage welding seam with 6 torches
2. High Throughput
3. Precisely control shrinkage deformation with real-time thermal and deformation monitors
4. Control welding current or torch moving speed with computer

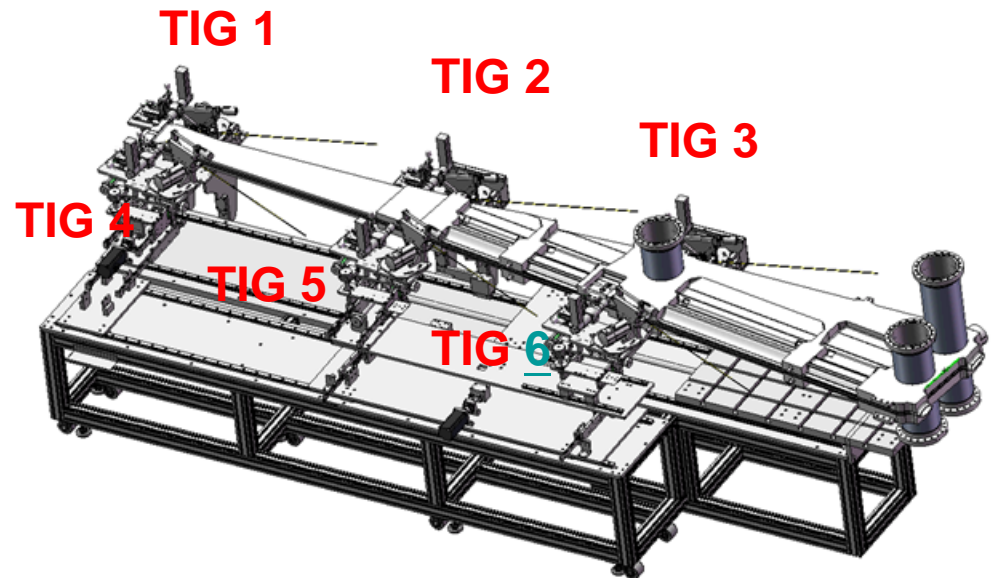

Side Welding Seam Locations

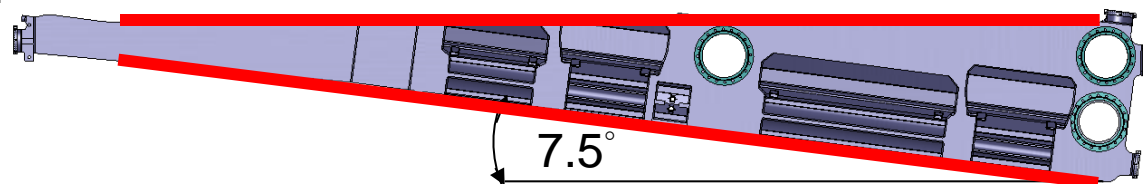

Welding Set Configuration

Torch can be adjusted precisely in x-, y- and z-direction

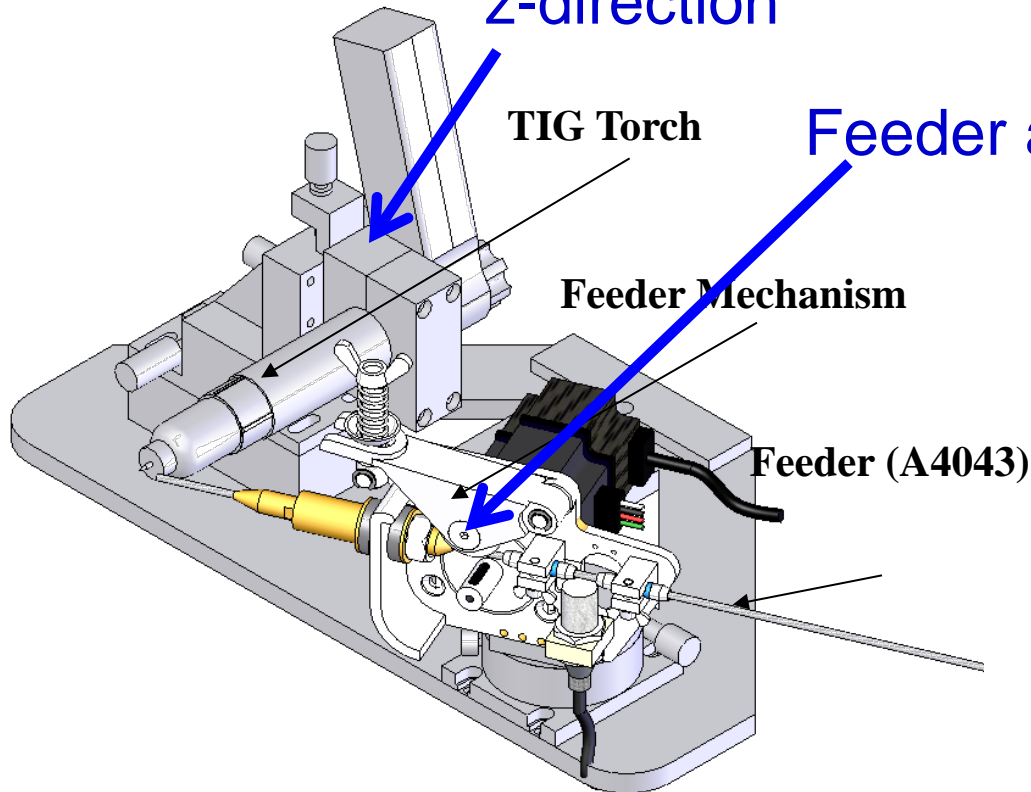

- The position between the torch and the filler in the auto-welding system is evaluated carefully, similarly to a human welding position.
- All motional axes are driven with servo motors.



Movies for Auto-Welding Process

- 6 TIG torches ignited at the same time
- 6 welding torches for two non-parallel side seams.
- One-step welding process



Fast playing mode: X10



Welding Seam Views

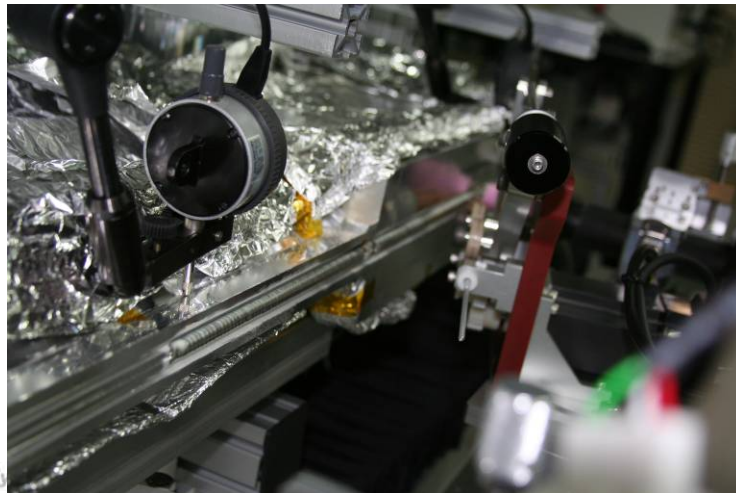
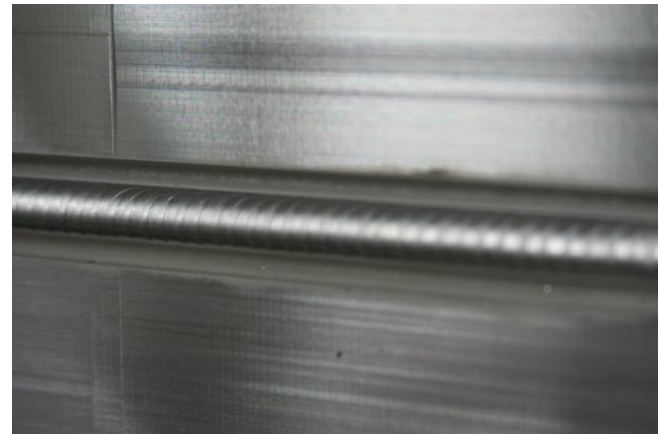
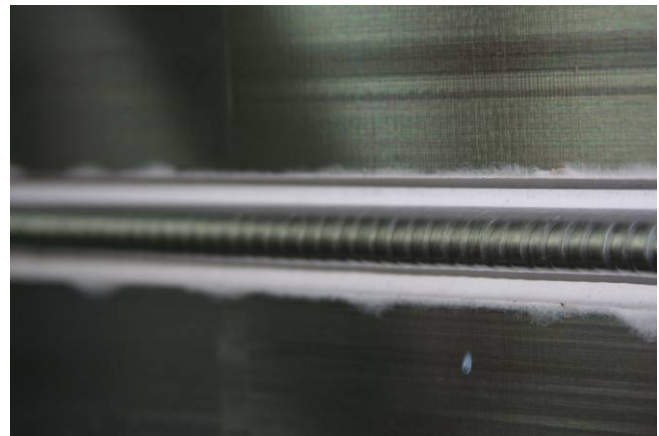
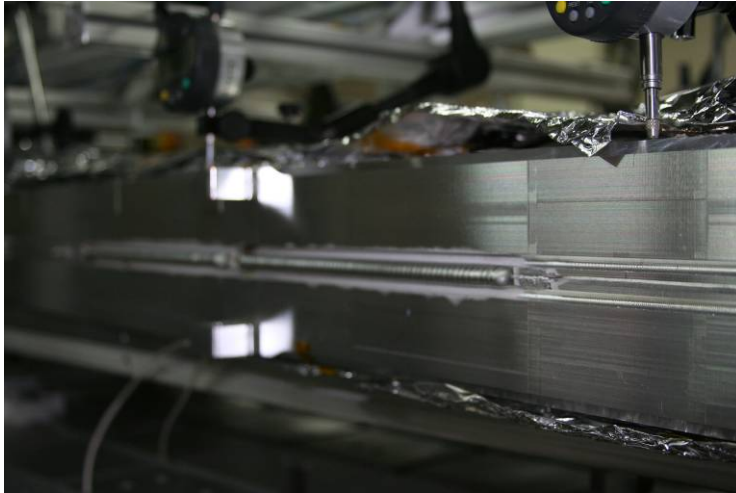

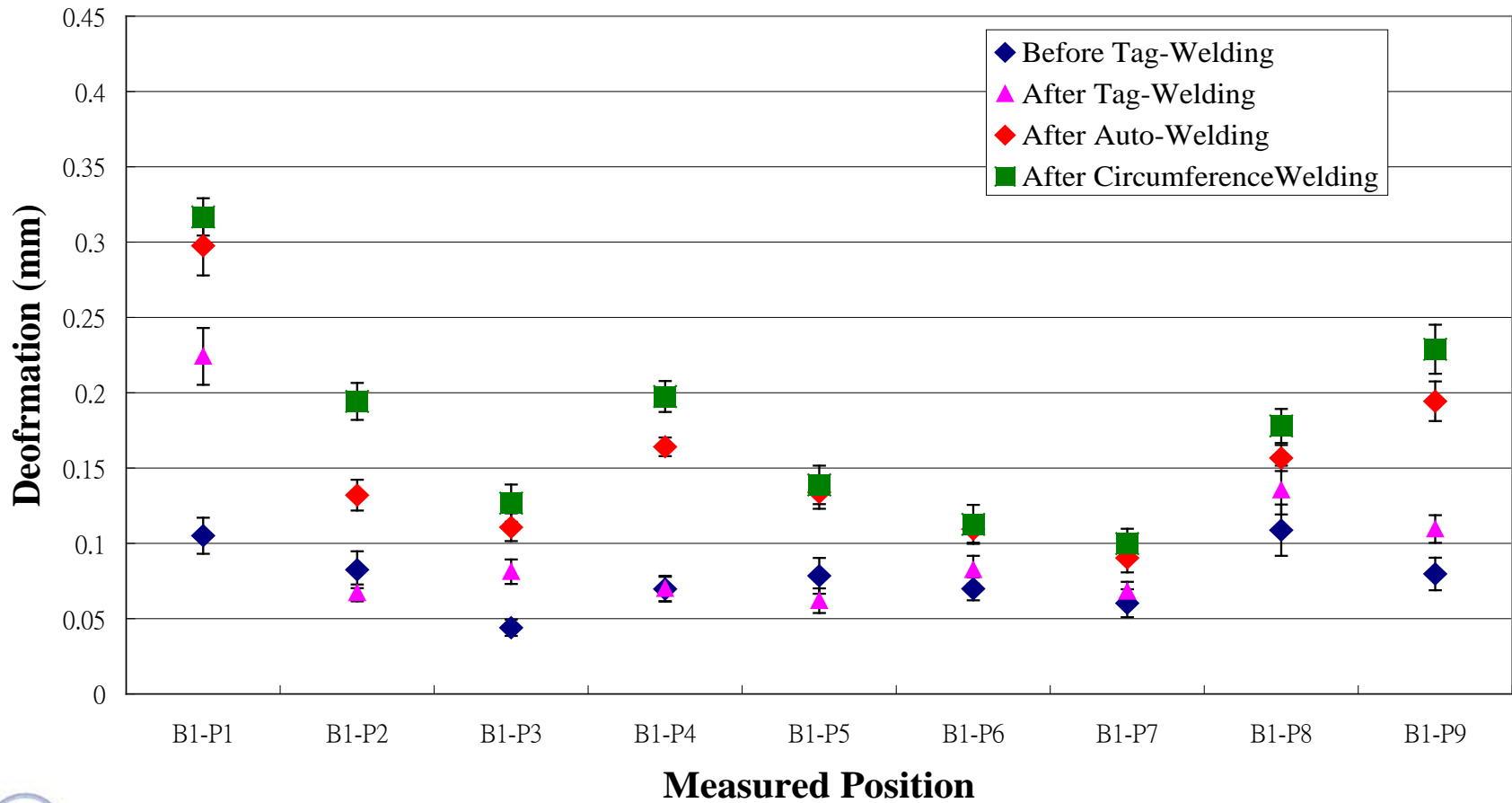
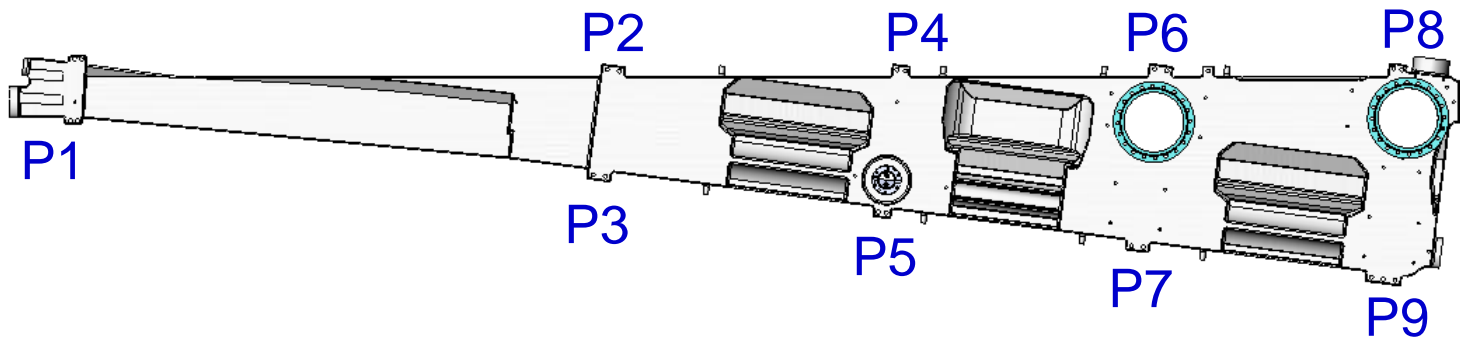

Mechanical Considerations Support and Alignment



- ❑ *Structural stands must provide deadweight support for the accelerator and beam line.*
- ❑ *Stands must provide support during seismic events.*
- ❑ *Stands must provide adequate freedom of movement during thermal cycles (operational and bake-out).*
- ❑ *Stands must constrain the accelerator and beamline to maintain positional requirements.*
- ❑ *There are two categories of supports:*
 - *Kinematic Supports - support system that provide some of six degrees of freedom (x, y, z, roll, pitch, and yaw).*
 - *Fully constrained Supports - support system that locks the vacuum system to control its position*

Six Degrees of Freedom

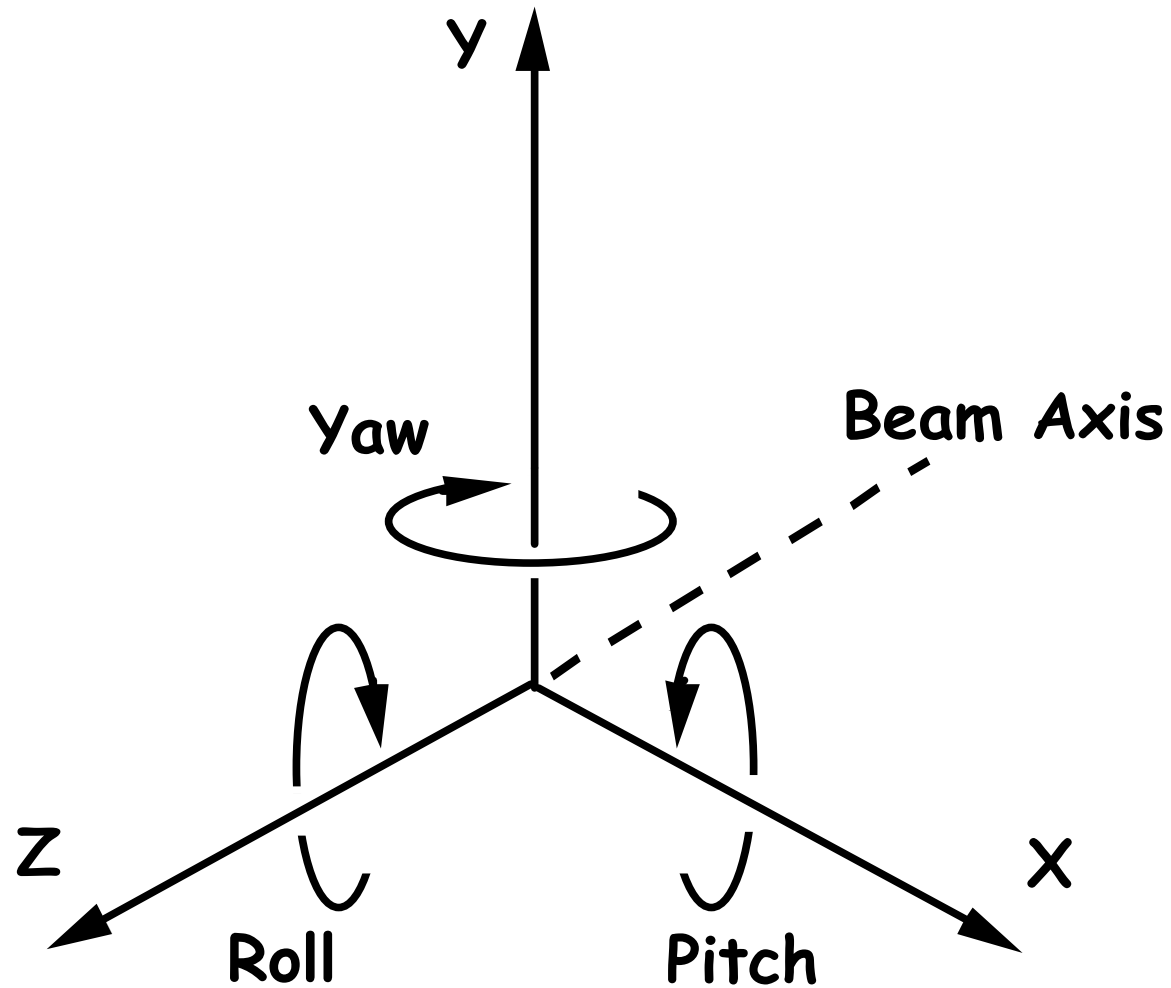
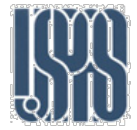

Y-direction Stand for PEP II Wiggler Chamber

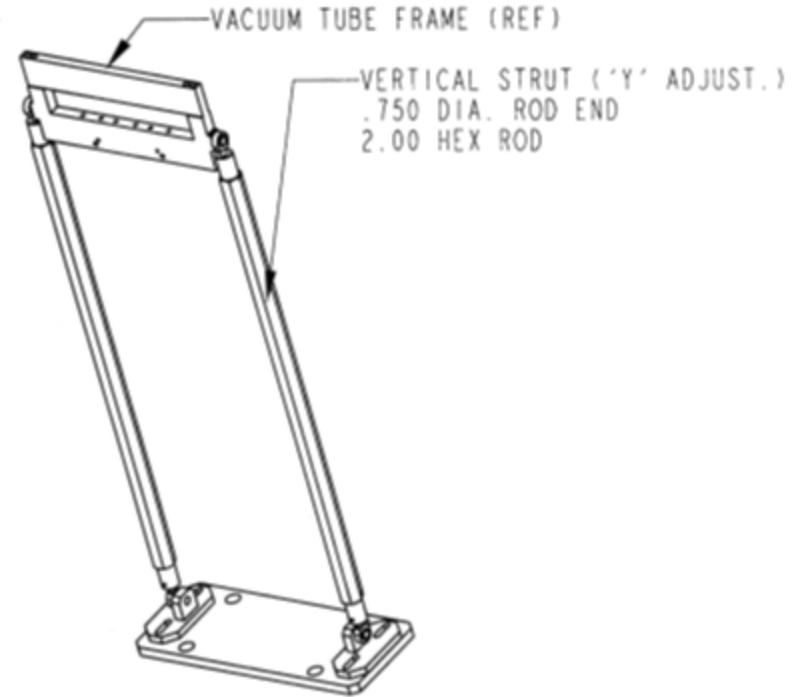

This stand provides support and adjustment capability in the y-direction and roll.

Supports provide X, Z translational freedom

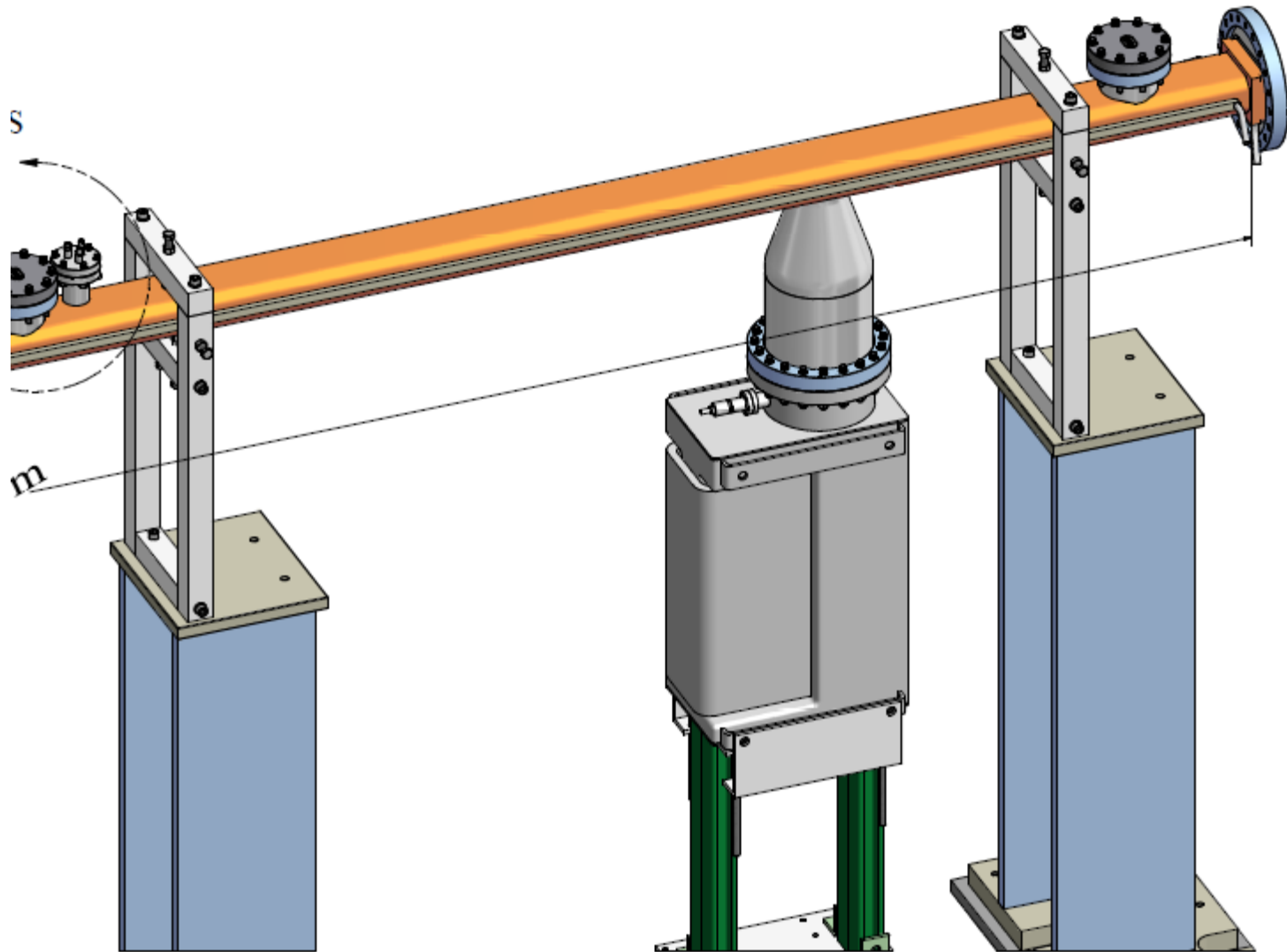

Supports provide Z translational freedom

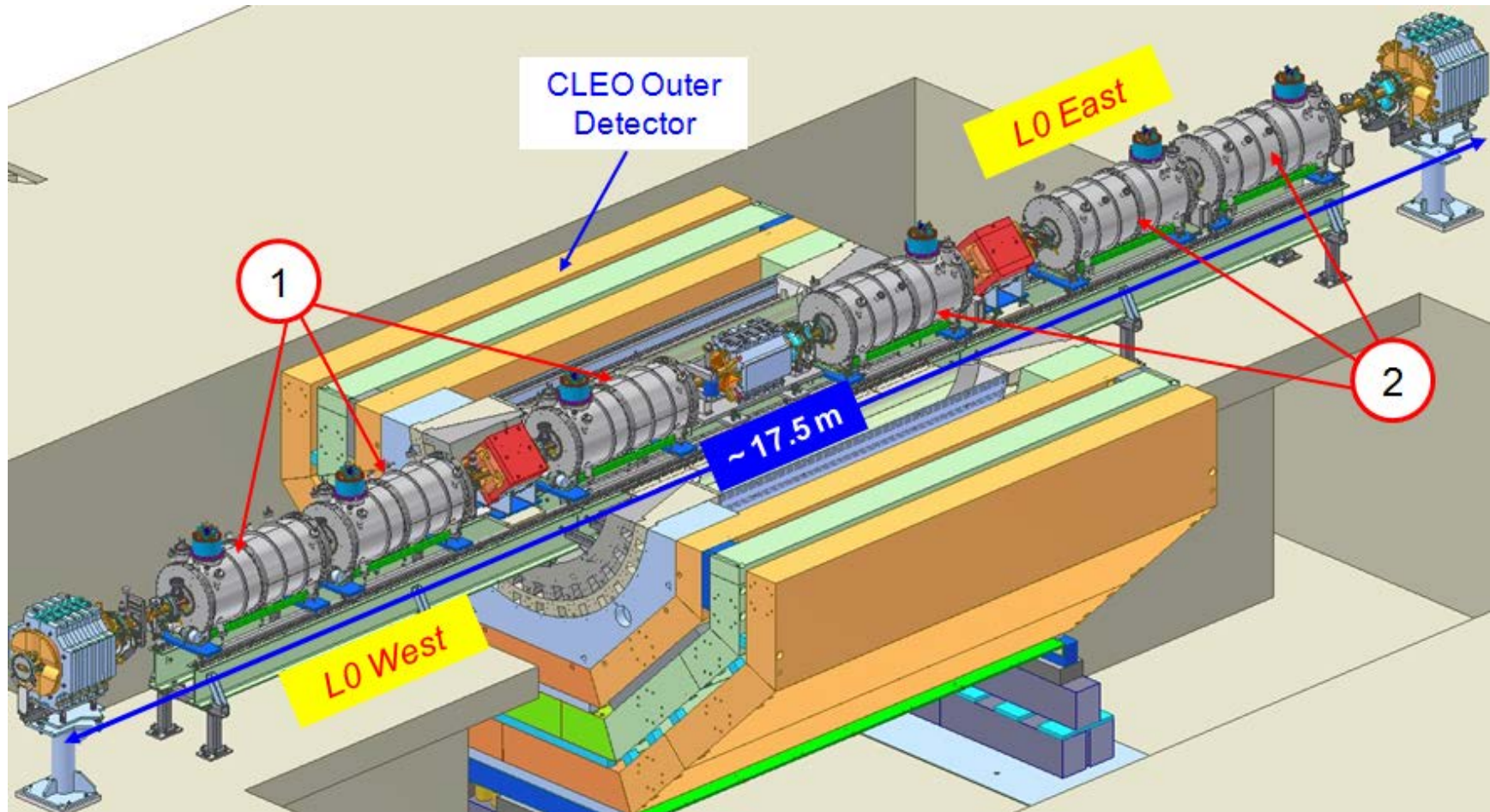

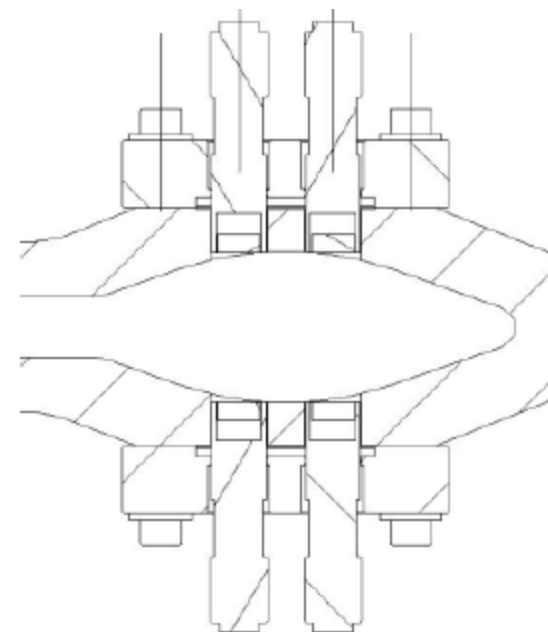
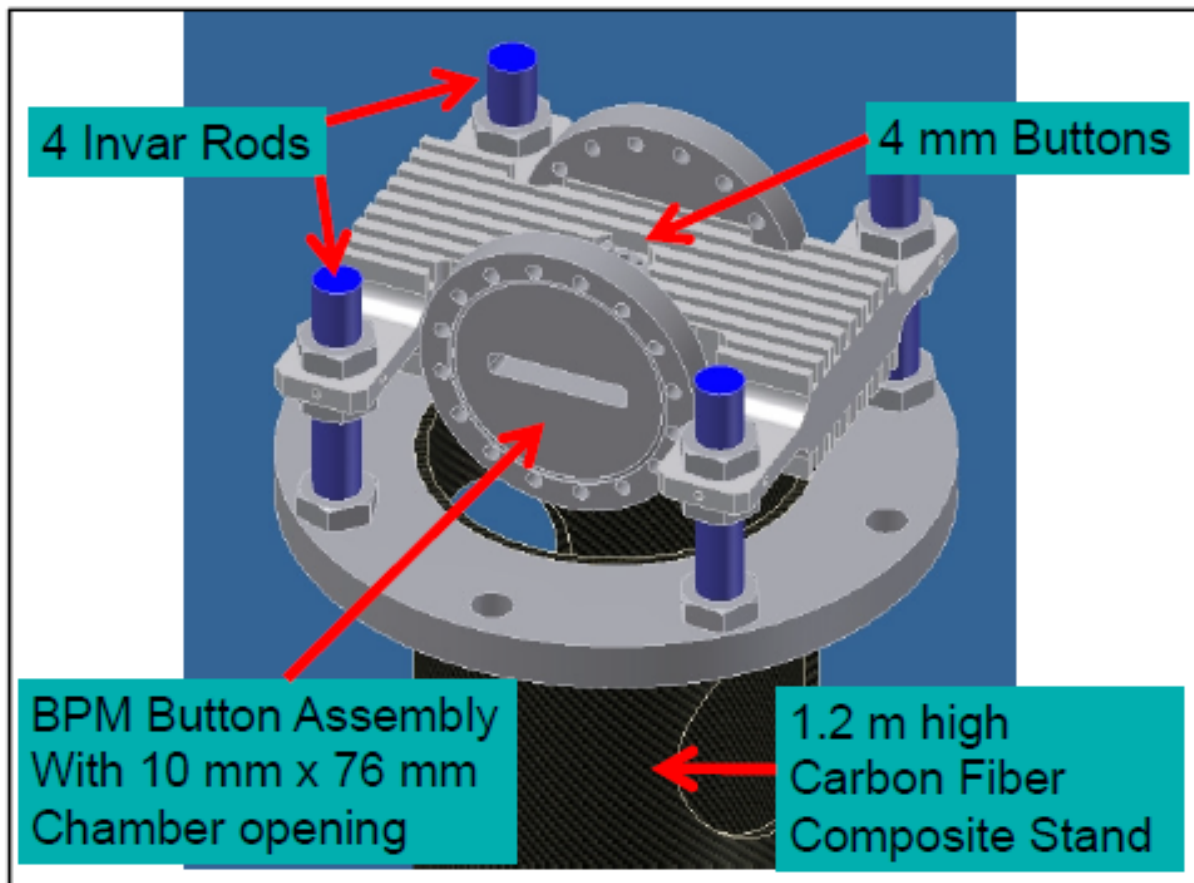

Fully Constraint Support – CESR Ceramic Pipe

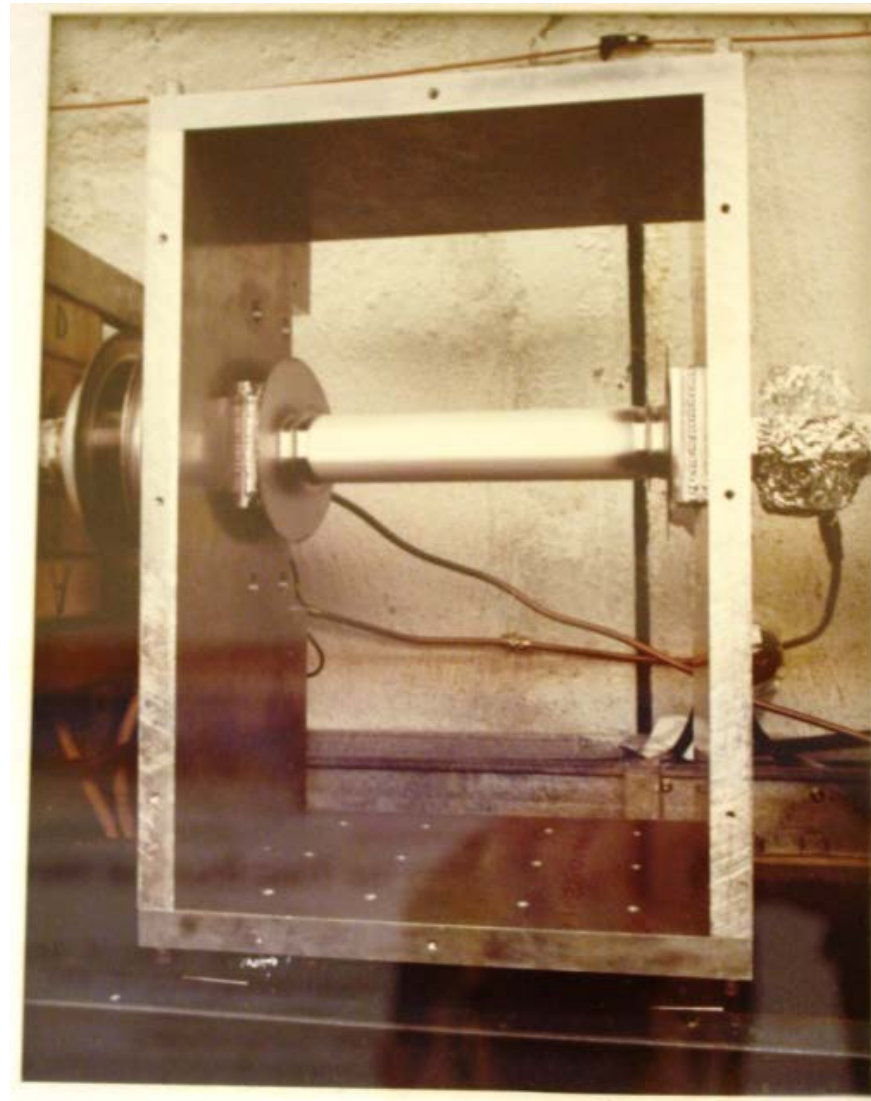

Six-Strut Support Systems

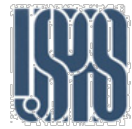

- A support system that uses six orthogonal struts to provide a "kinematic" support (just enough support with no additional constraints).
- Struts have spherical ball joint end connections.
- Each strut is extremely strong and rigid.
- Together the six struts can usually provide a support system with a natural frequency greater than 20 Hz, to eliminate nearly all floor transmitted vibration.
- An excellent reference for this style of support system is: "Rigid, Adjustable Support of Aligned Elements via Six Struts", W. Thur et al, Fifth Int. Workshop on Accelerator Alignment, 1997

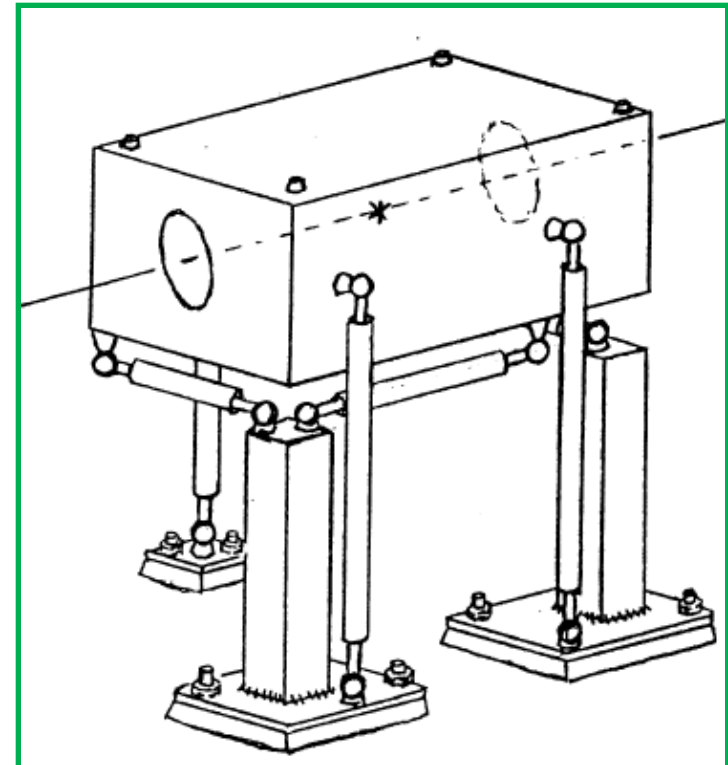
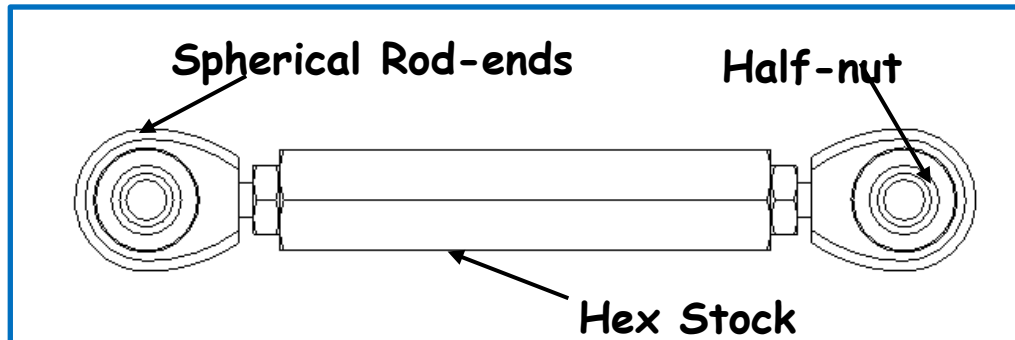

Example of Kinematic Supports (six-strut)

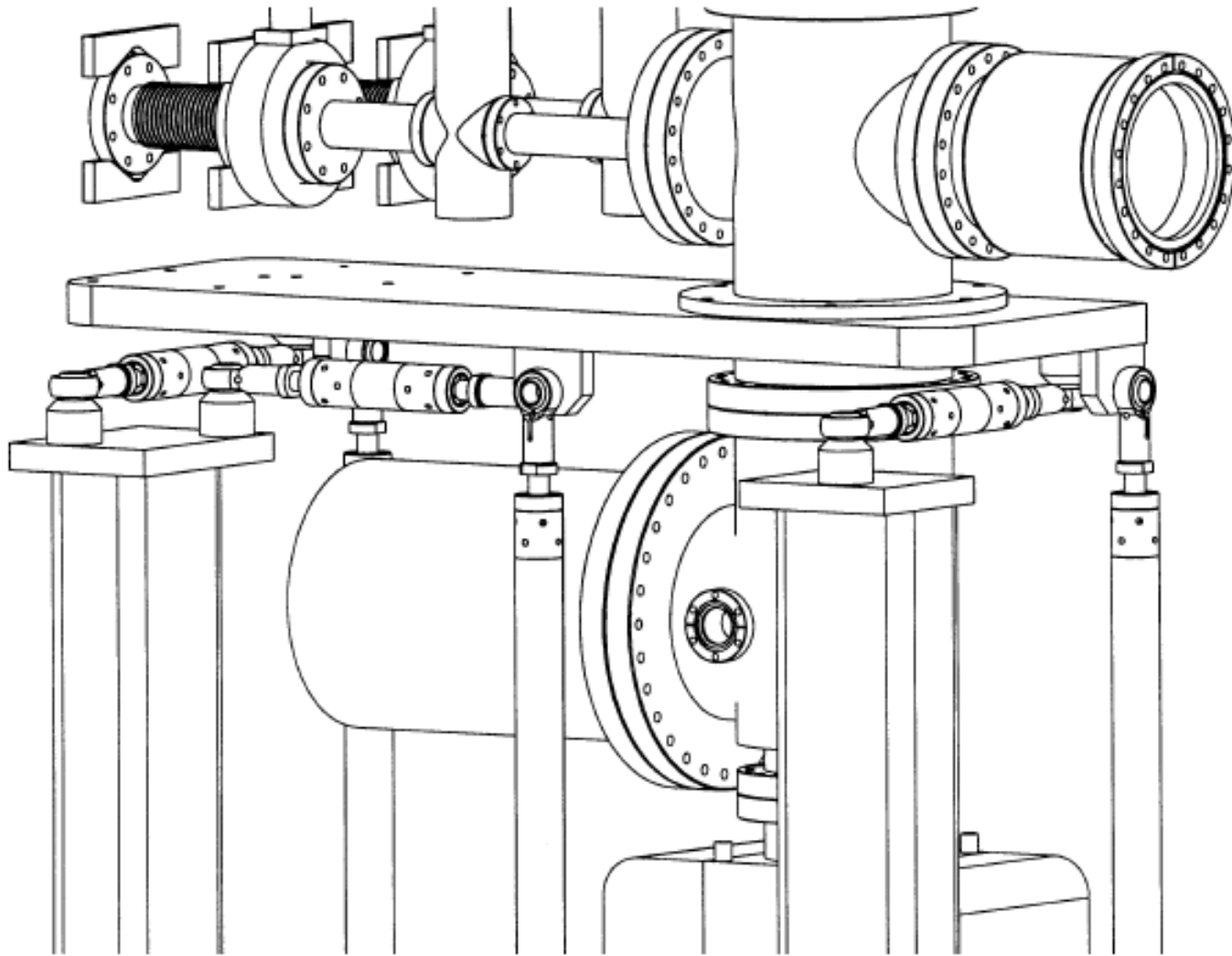

Vacuum Chamber and Magnet Girders



At NSLS II, ~150 girders were assembled and aligned.

- Multipole magnet alignment requirements
 - Vertical ± 30 microns
 - Transverse: ± 30 microns
 - Longitudinal: ± 500 microns
 - Roll: $\pm .5$ mrad
 - Pitch: ± 1.0 mrad
 - Yaw: ± 1.0 mrad

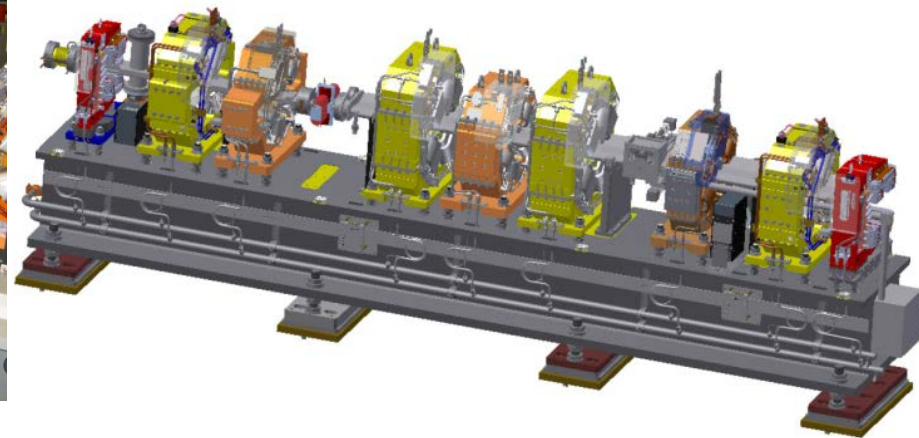
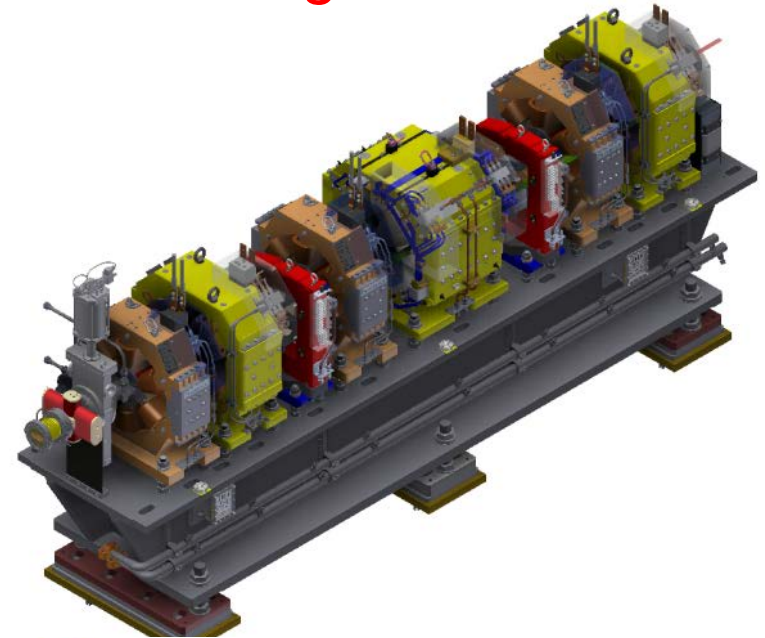

Last minute improvises ...

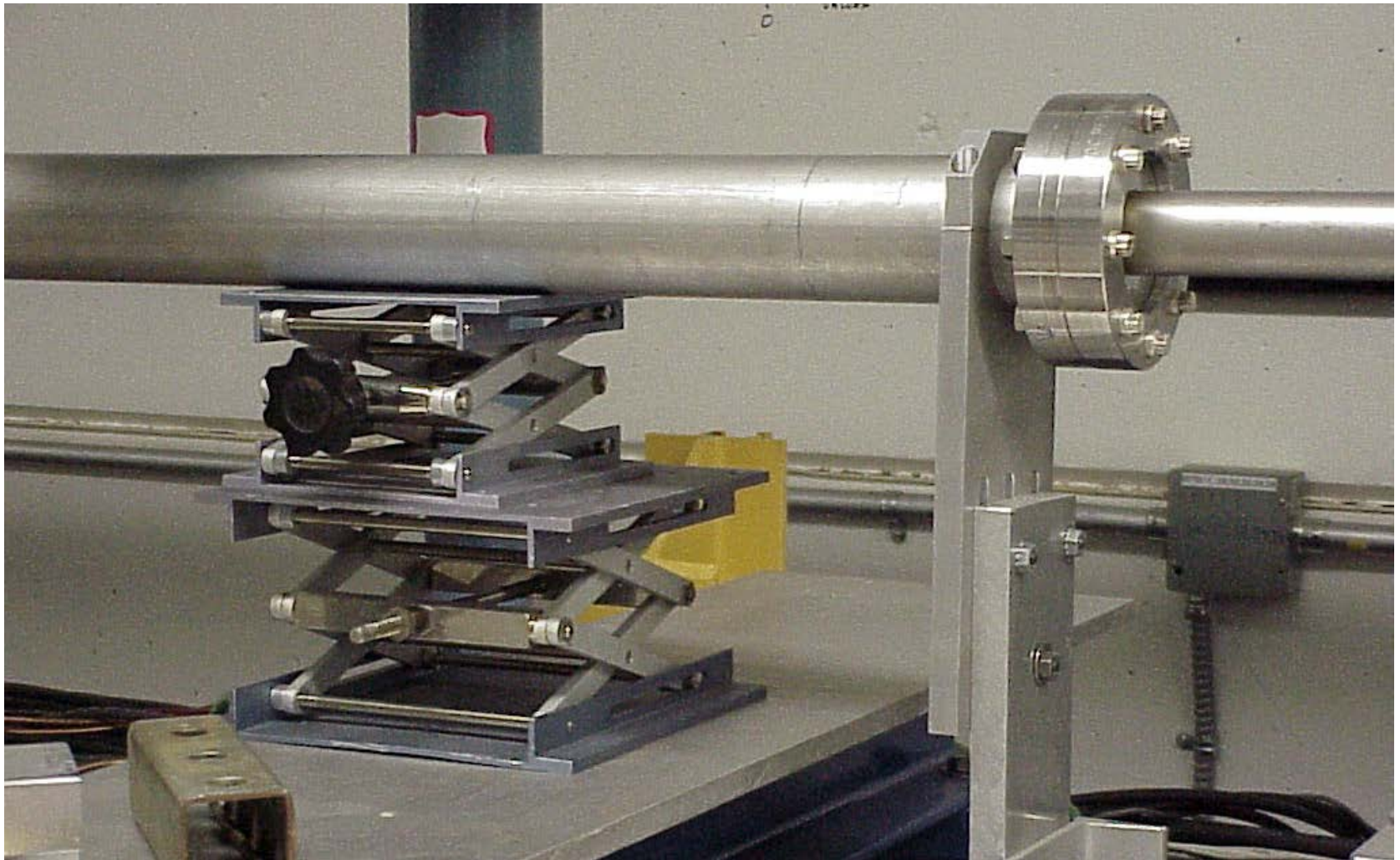



- *Most modern accelerators have very tight tolerance on components' alignment, including vacuum components, and equipped with laser-based survey instrument to measure and to achieve the required accuracy in alignment.*
- *With modern laser trackers and network of reference monuments, positions of any component can be located better than 0.1 mm in a accelerator complex.*
- *It is essential to build in survey features (such as monuments, fiducials) on critical vacuum chambers that contain critical accelerator components. Typical areas of accelerator vacuum systems that require accurate positioning.*
 - ❖ *RF cavities*
 - ❖ *Beam position monitors (BPMs) and other beam instrumentations*
 - ❖ *Synchrotron radiation absorbers and masks*
 - ❖ *SR producing insertion devices (undulators, wigglers, etc.)*

Fiducials on a Wiggler Chamber (near BPM)

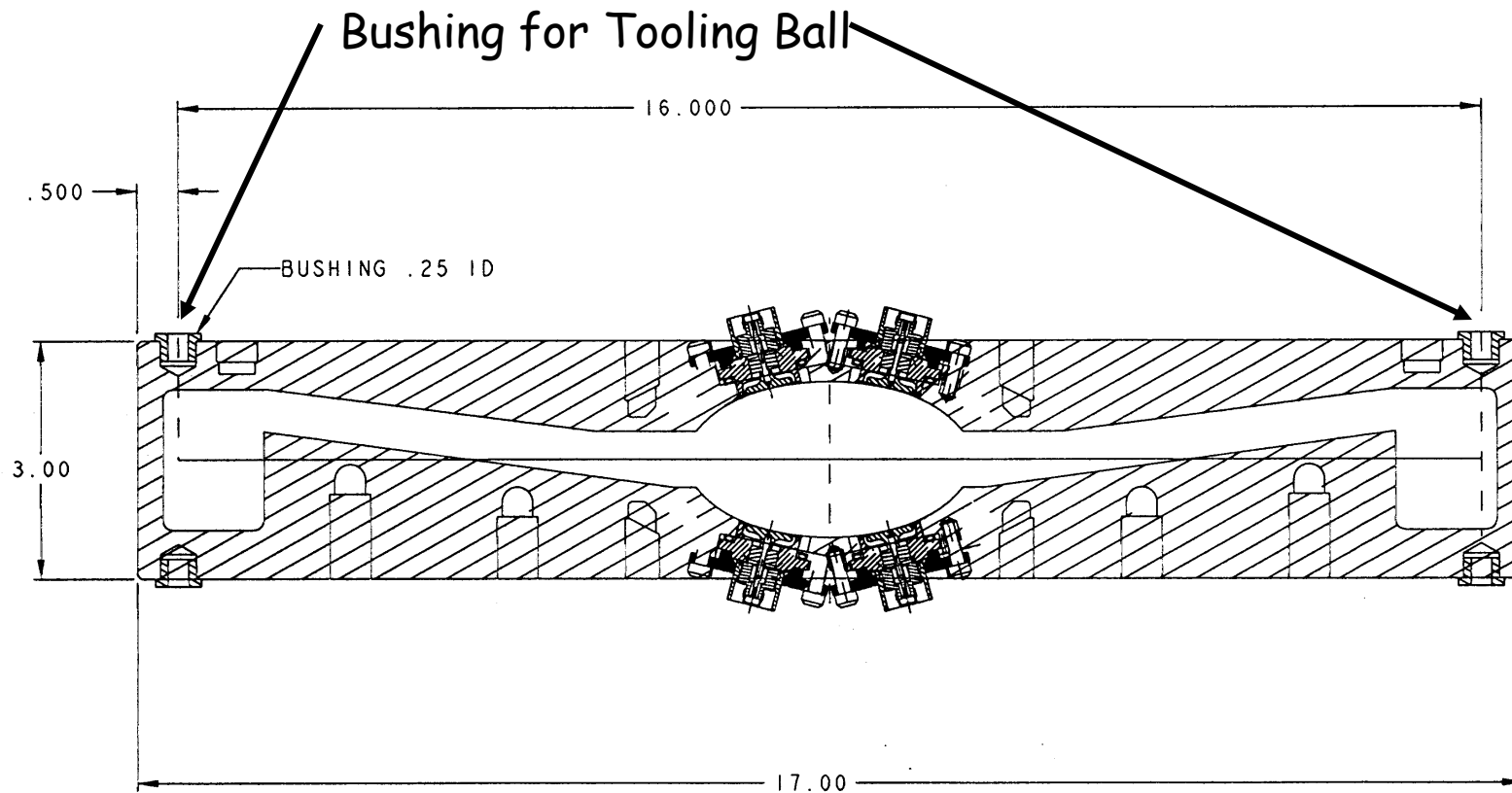

Fiducials on an Optical Diffraction Monitor

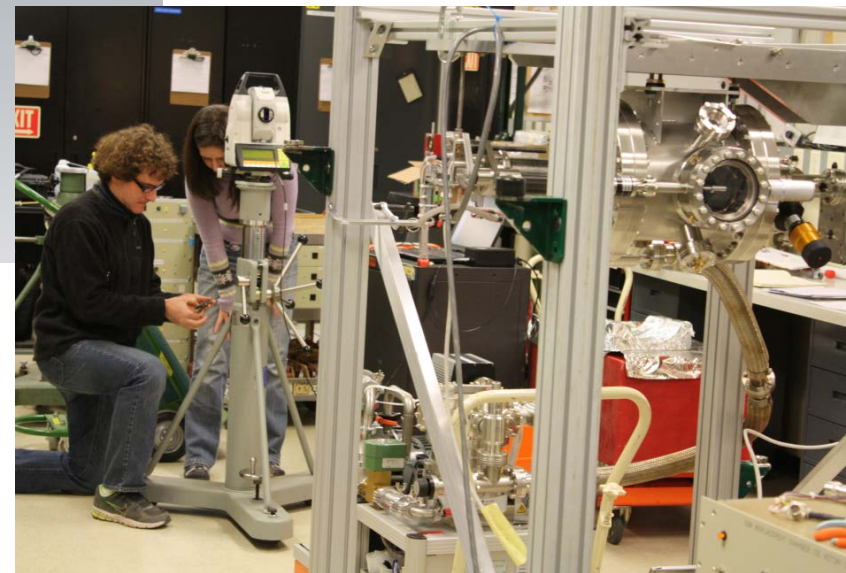
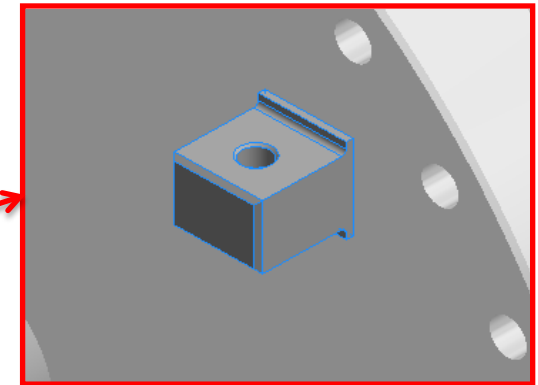
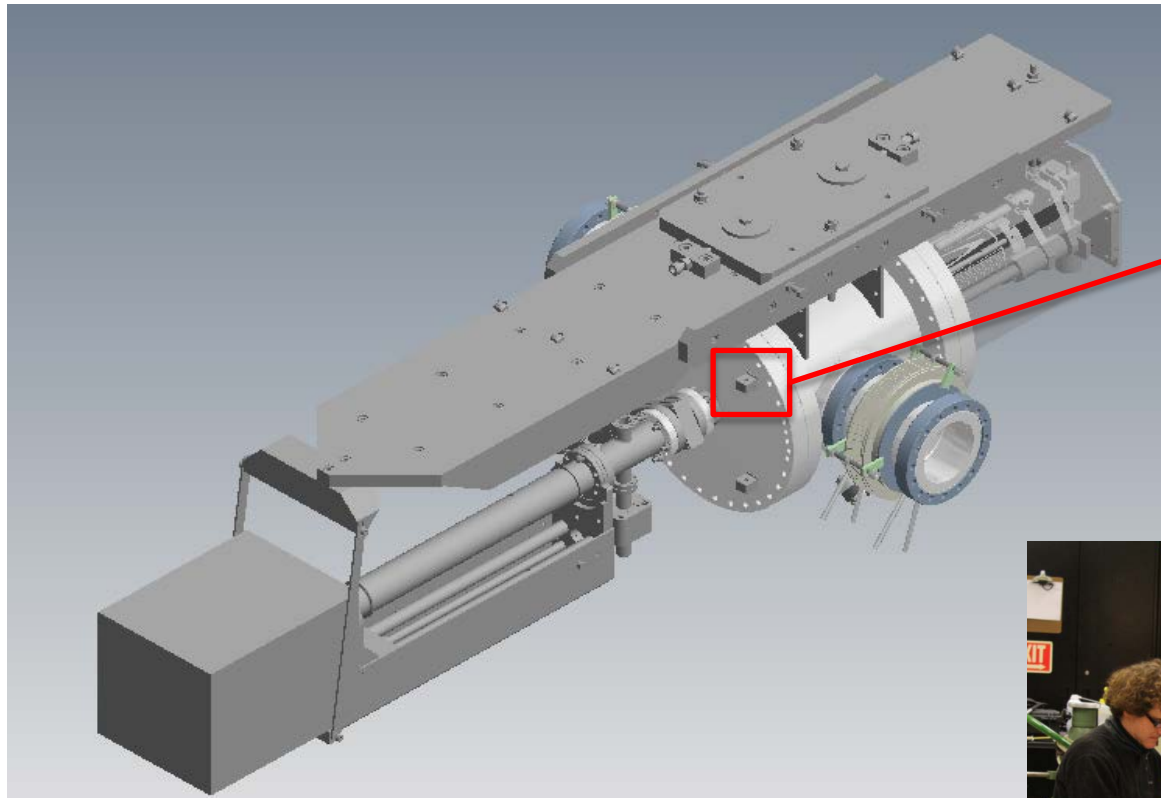

- *Build-in fiducials were pre-surveyed, referencing to ODR 'target'*
- *The established fiducials are used to locate hidden ODR target during installation*

Leak Checking

Why Leak Checking?



- ❑ For a clean vacuum system, leak(s) may limit the achievable ultimate pressure.
- ❑ Even for relatively small leak, certain types of molecules in the gas may affect accelerator performances (such as Ar, O₂, H₂O, etc.) For example, Ar atoms have much higher beam-gas scattering cross-section, as compared to hydrogen; O₂ and H₂O may 'poison' surfaces of electron gun cathodes (both photo-emitting or thermionic emitting).
- ❑ Leak may have impact on long term performance of the vacuum systems, especially for getter-pump dominated systems.
- ❑ Leak (even small) may be a sign of defects on a vacuum joint that may develop into operational issue.

Outgassing Vs. Leaking



- ❑ Pressure goes up with time in a closed off, pumping-free chamber.
- ❑ The rising of the pressure may due to outgassing from the inner walls, or due leak(s).
- ❑ For outgassing, pressure will only rise to a level of saturated vapor pressure of evolved molecules.
- ❑ For a leaky system, pressure rises linearly with time.

1. Leak
2. Outgassing
3. Leak + outgassing

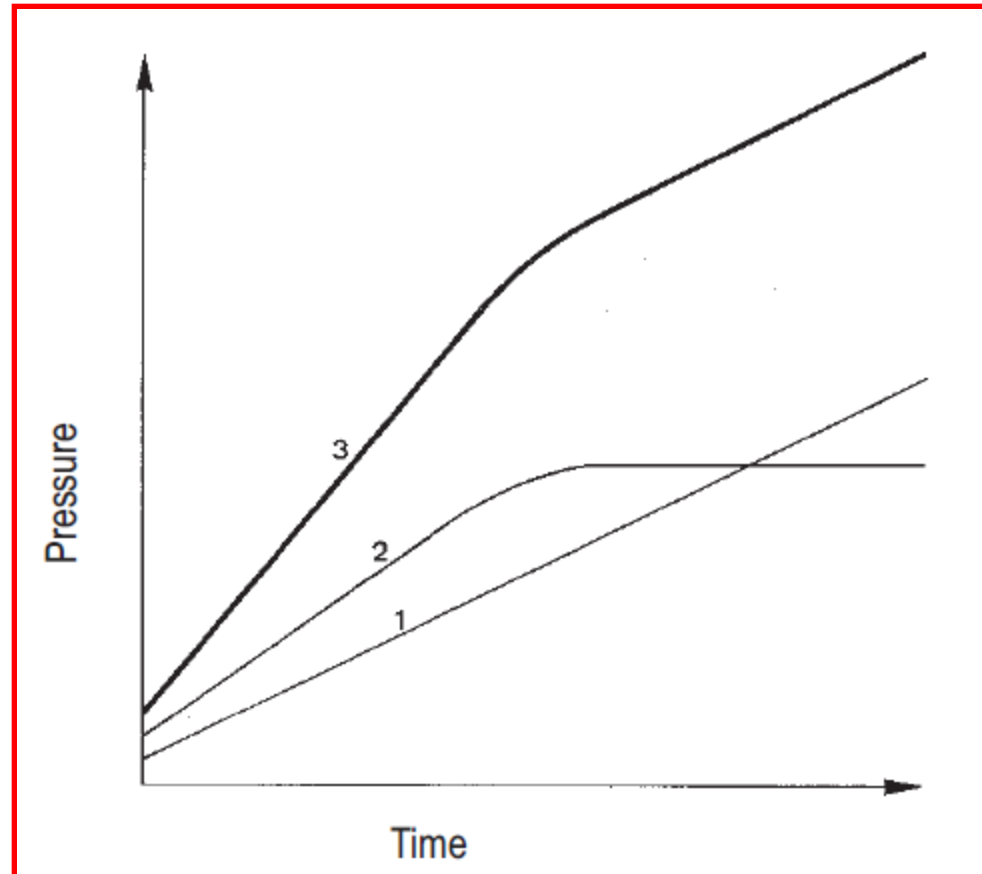

Types of Leaks



- *Leaks in detachable connections: flanged joints*
- *Leaks in permanent joints: welded seams, brazed seams, bonded zones*
- *Leaks due to porosity: particularly following mechanical deformation (bending!), or thermal processing of cast components*
- *Thermal leaks (reversible): opening up only at elevated temperature or/and under loading*
- *Virtual leaks*



Leak Rate and Size

- ❑ No vacuum system is absolutely leak free, and it does not have to be! In practice, an "acceptable" level of leak is specified by the system requirement.
- ❑ To quantify a leak, a leak rate is define as a specific gas throughput rate though a leak into a vacuum system. In US, unit of torr· liter/sec (STP) is often used.
- ❑ A leak rate of $Q_L = 1 \text{ torr} \cdot \text{l/s}$ is present when in an enclosed, evacuated system with a volume of 1-liter, the pressure within rises by 1 torr per second, at standard temperature and outer pressure (STP, usually 25°C and atmosphere pressure)

Correlation between leak rate and hole size

Hole Size (mm)	1	10 ⁻¹	10 ⁻²	10 ⁻³	10 ⁻⁴	10 ⁻⁵	10 ⁻⁶	10 ⁻⁷
Leak Rate (torr·l/s)	10 ⁺²	1	10 ⁻²	10 ⁻⁴	10 ⁻⁶	10 ⁻⁸	10 ⁻¹⁰	10 ⁻¹² (Detection Limit)

Ref. Fundamentals of Vacuum Technology, Oerlikon Leybold Vacuum, 2008





- Leak Detection should be performed in accordance with some ASTM Standard.
 - **ASTM E432-91 (2004)** "Standard Guide for the Selection of a Leak Testing Method"
 - **ASTM E479-01(2006)** "Standard Guide for the Preparation of a Leak Testing Specification"
 - **ASTM E493-06** "Standard Test Methods for Leaks using Mass Spectrometer Leak Detector in the Inside-Out Testing Mode"
 - **ASTM E498-95 (2006)** "Standard Test Methods for Leaks using Mass Spectrometer Leak Detector or Residual Gas Analyzer in the Tracer Probe Mode"
 - **ASTM E499-95 (2006)** "Standard Test Methods for Leaks using Mass Spectrometer Leak Detector in the Detector Probe Mode"
- Leak Detection should be performed in a series of logical steps.

Leak Detection Methods

1. Vacuum method - Outside-in

- *Acoustic*
- *Mass Spectrum Leak detector*
- *Residual gas analyzers*
- *Rate-of-rise*
- *Vacuum gauges sensitivity variation (helium vs. air/N₂)*

2. Positive pressure method - Inside-out

- *'Bubbling'*
- *Foam spray*
- *'Sniffing' with a leak detector*
- *Pressure drops*

Helium is the most common gas used as a "tracer"



When compared to other gases, helium has certain advantages as a tracer:

Low molecular weight

High intrinsic velocity

Small molecular size

Chemically inert

Non-flammable

Readily available

Inexpensive

Low partial pressure in the atmosphere

Some disadvantages are:

Is not well pumped by ion or chemisorption pumps

Is not well pumped by cryogenic pumps

Other gases may be used as tracer:

HD ($m/e=3$) may be used for environment with very high helium background

Leak Detection – Localized or Integral

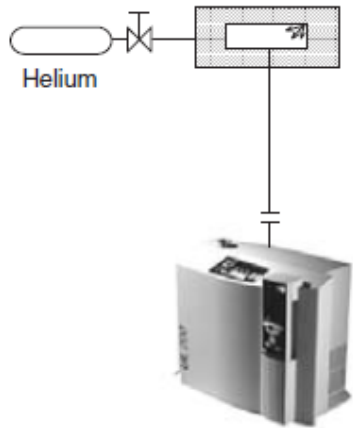

a: Integral leak detection; vacuum inside specimen

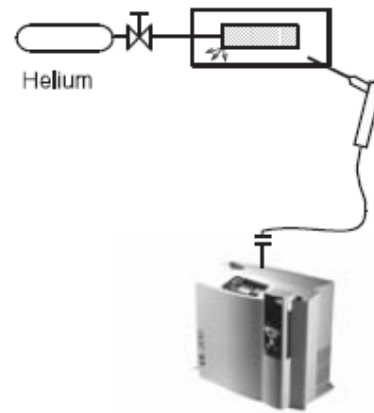

c: Integral leak detection (test gas enrichment inside the enclosure); pressurized test gas inside specimen

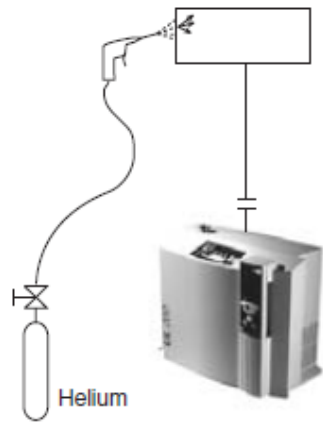

b: Local leak detection; vacuum inside specimen

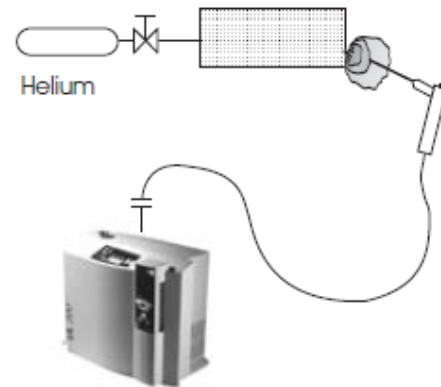

d: Local leak detection; pressurized test gas inside the specimen



- It is a Helium-specific partial pressure analyzer
- It detects Helium applied as a tracer or probe gas
- It consists of:
 - a mass spectrometer tube
 - it's own vacuum system capable of $<10^{-5}$ Torr in the spectrometer tube
 - a sensitive and stable amplifier
 - valves, and auxiliary pumps for interfacing to vacuum system
 - a display for monitoring leak rate
 - normal-flow vs. contra-flow configurations

Helium Leak Detector Cont.

- 180° sector magnet mass spectrometer is most common in commercial helium leak detectors, due to compactness and robustness.
- Depending on vacuum pressure in test port, the mass spectrometer may connect to test specimen directly (direct-flow), or indirectly (contra-Flow)

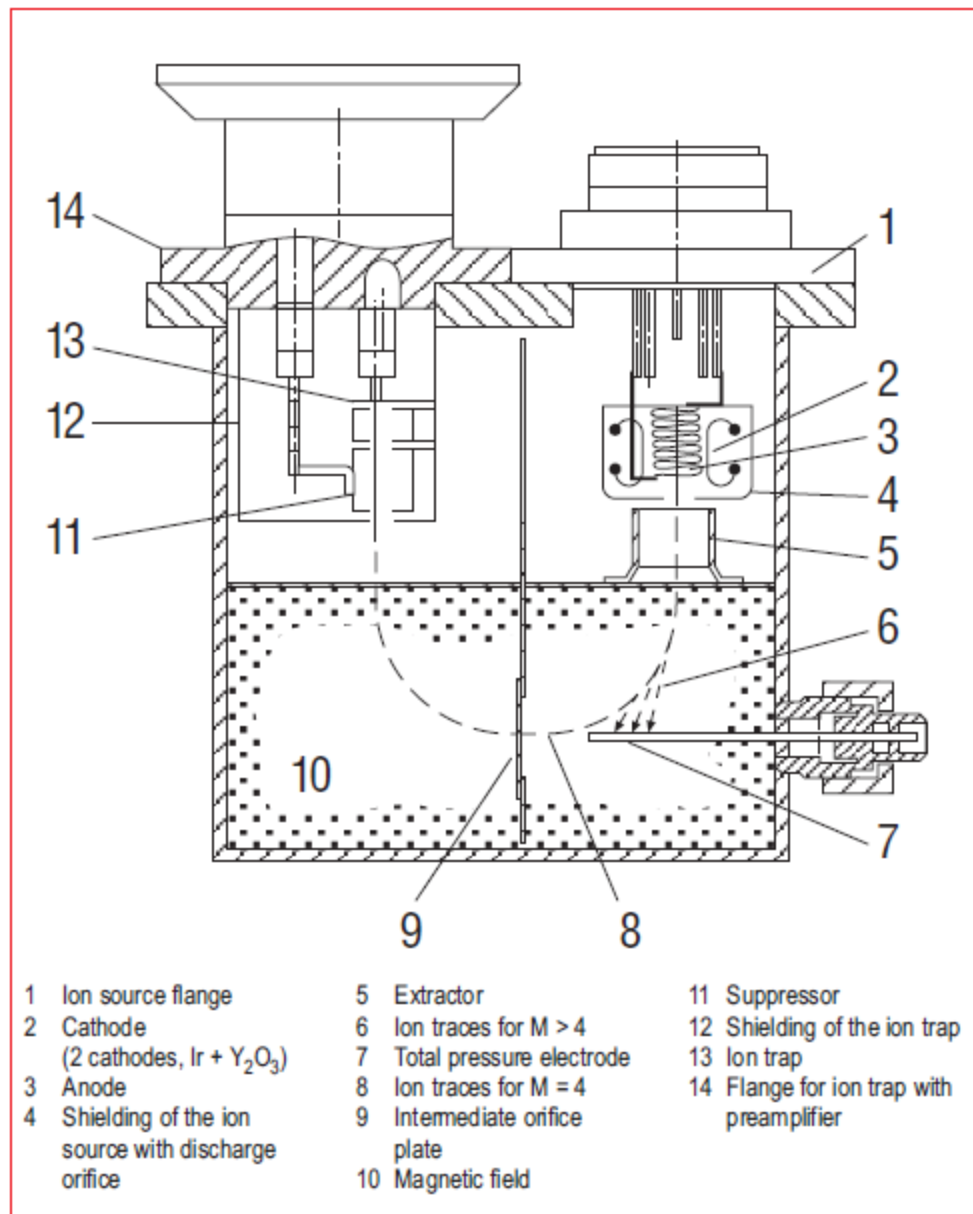

Direct Flow Schematics



Mass spectrometer is exposed to all gases pumped through the Leak Detector.

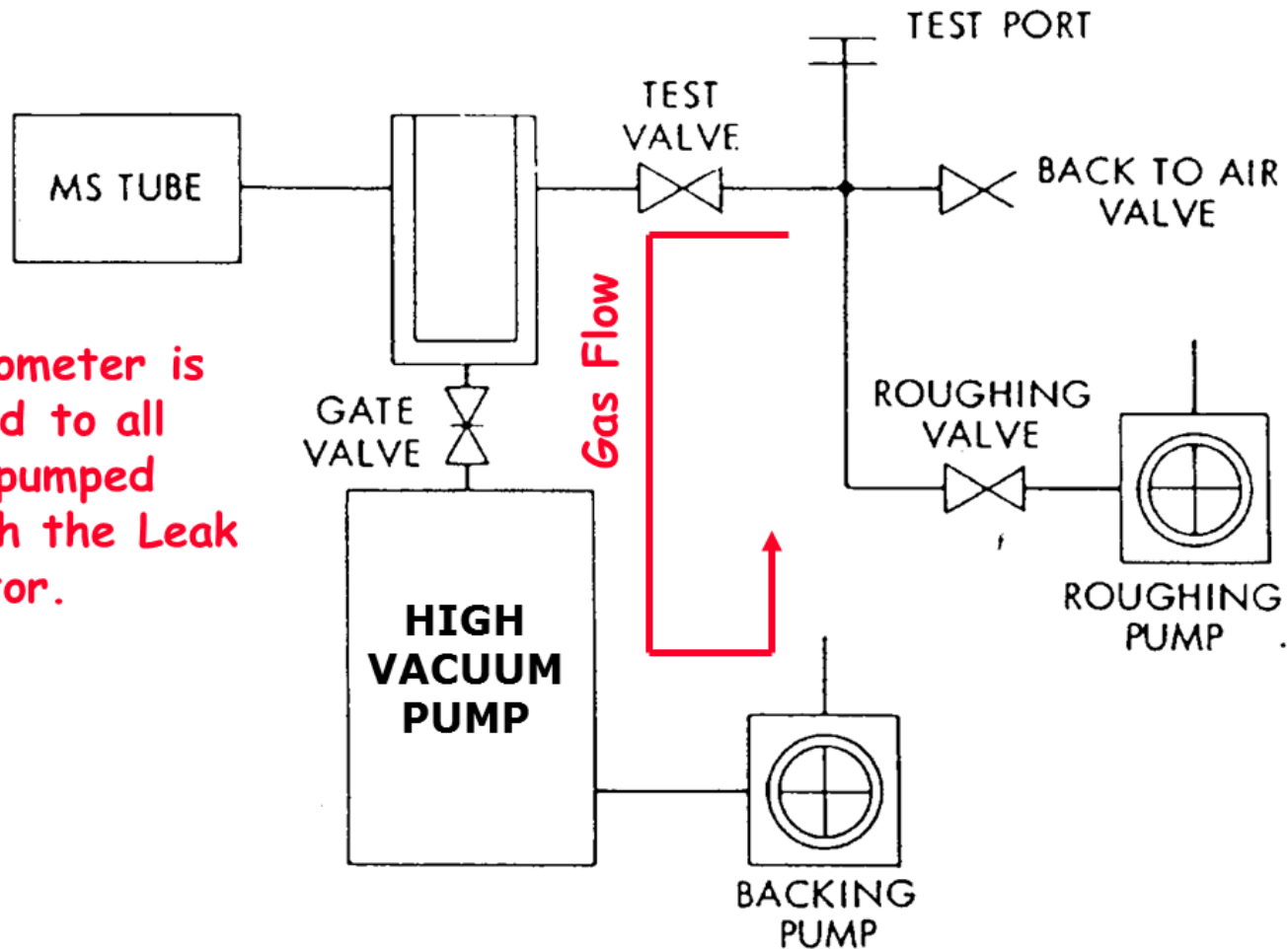

Schematic of Contra-flow Configuration



Mass spectrometer is exposed only to gases that backstream through the high vacuum pump.

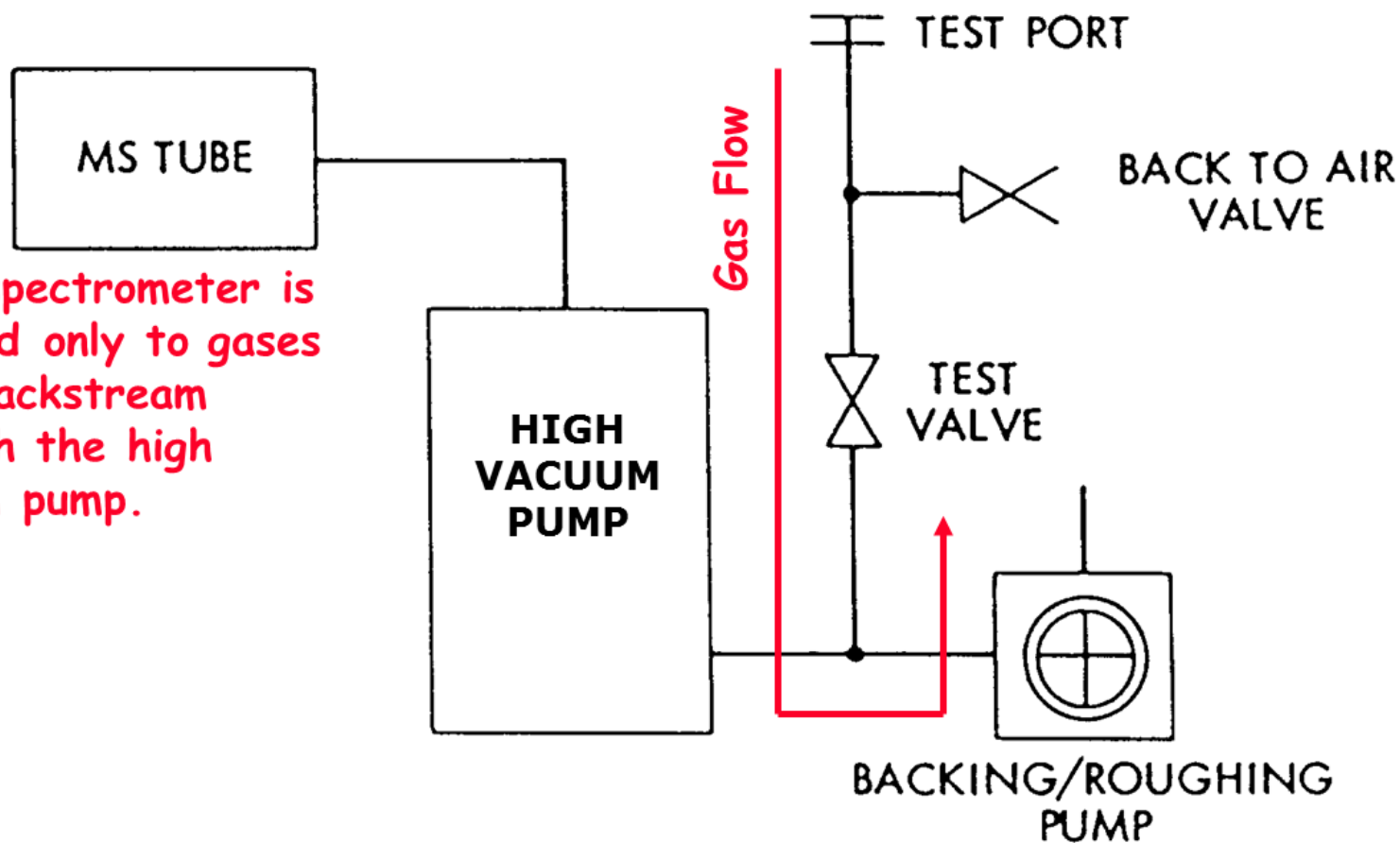

Leak Detector Calibrations

- ❑ *Majority of commercial leak detectors have build-in calibrations*
- ❑ *Calibrated helium leaks are also available in ranges of 10^{-3} to 10^{-10} torr·l/s.*



Leak Check – A key step in QC



- *Leak check is the most critical measure of vacuum system quality assurance and control.*
- *For complex system, every vacuum components must be leak checked prior to installation, particularly for those components difficult to access in the field.*
- *For vacuum chambers that involve multiple vacuum brazes and welding, intermediate leak checking may be necessary. In most those cases, leak check fixtures should be designed and prepared.*
- *Components and chambers with small volume may use helium leak detector, while large vacuum chambers and systems will need a turbo pump equipped with RGA and calibrated helium leak.*

Major Leak Testing Problems



- Background (outgassing)
- Large Volumes, slow pumping speed for Helium
- Helium permeation and back-stream
- Leak "plugging"
- Detector maintenance
- Operator training

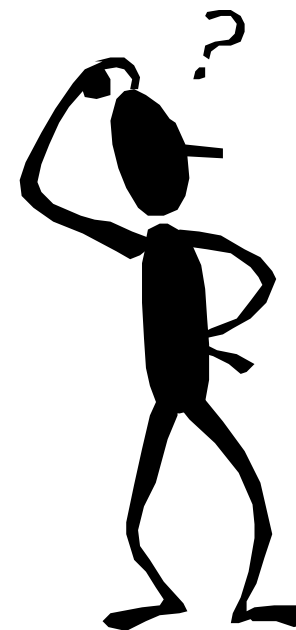

Recognize potential leak with a RGA

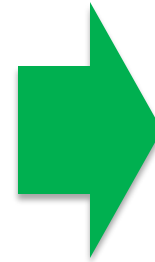
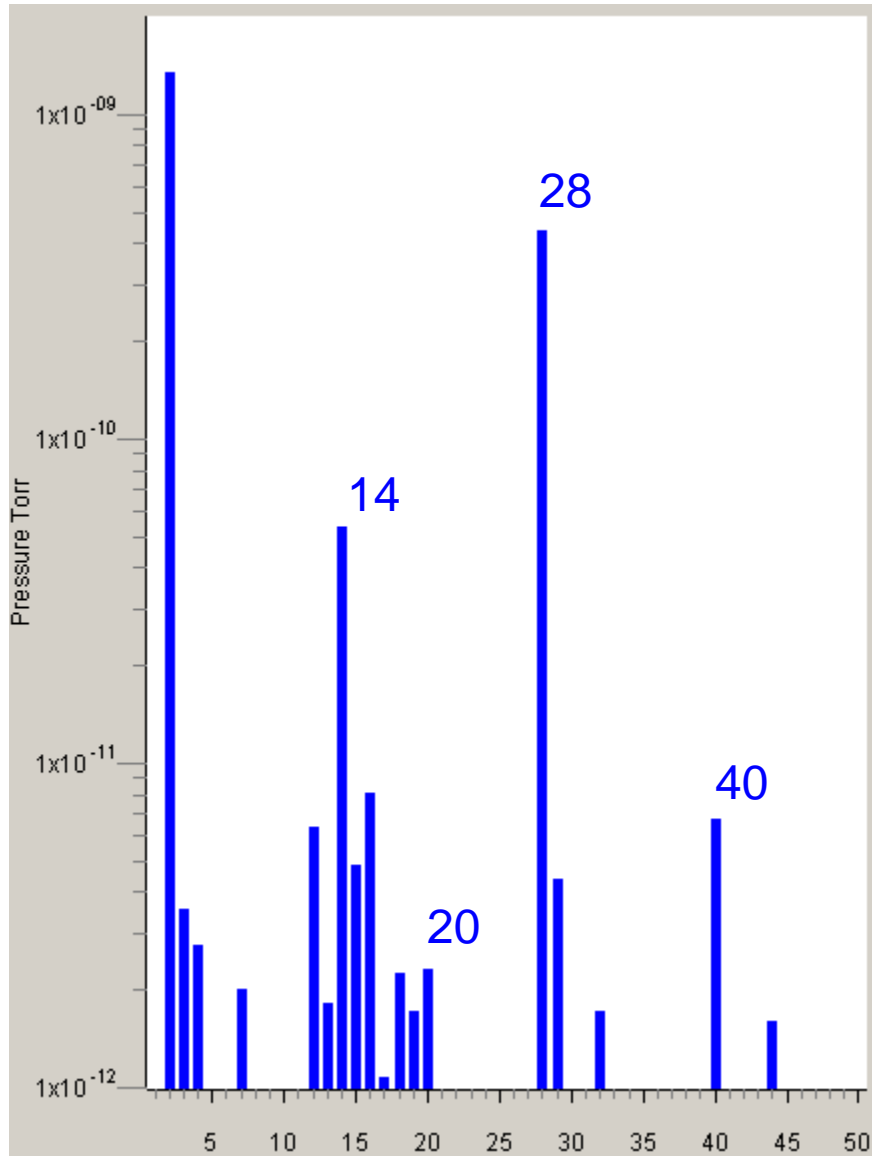

Vacuum system with a small air-to-vacuum leak!

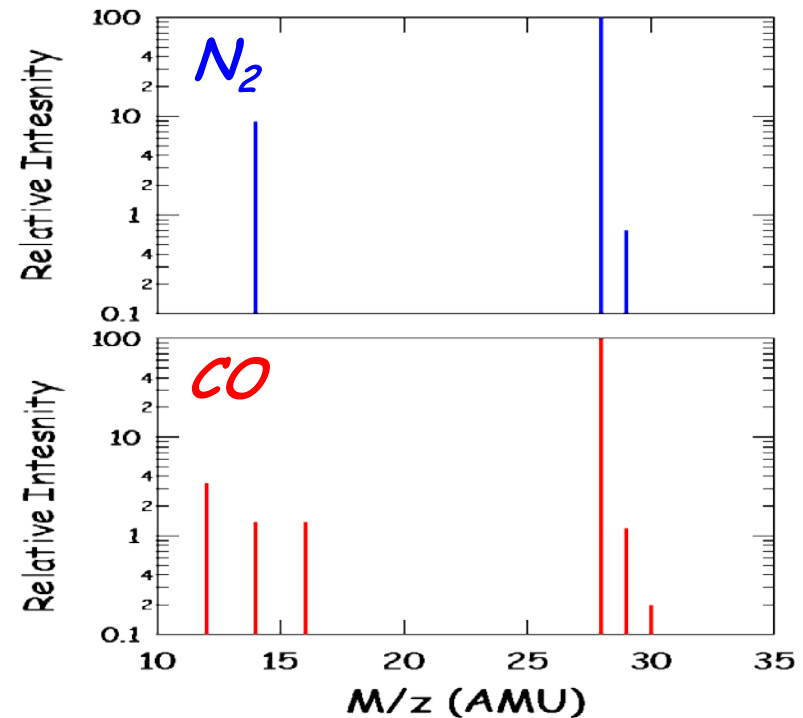

Leak Detection, Tips & Tricks

- *Always test the connecting lines first!*
- *Isolate O-rings to prevent permeative "masking" of real leaks*
- *Slow down tracer (helium) flow rate, with solvent "bubbling calibration"*
- *When introducing helium, start at top and work down (Tracer probe)*
- *Know the air flow. Start from down-stream and work up-stream.*
- *Avoid "plugging" potential leak(s)*



- *Flow all pumped gases through the HMSLD., or the RGA, if possible, turning off all other system pumps*
- *Use low-flow tracer probe technique*
- *Keep Helium away from permeable materials (elastomers)*
- *Make use of "bagging" and "taping" techniques*

When the system does not pump down:

- Inspect the obvious - loose gasket, open valve, etc.*
- Acoustic method - listen to the hissing, use a stethoscope*
- Positive pressure and use "bubbling" or sniffing methods, if permissible*
- Use additional backing pump*

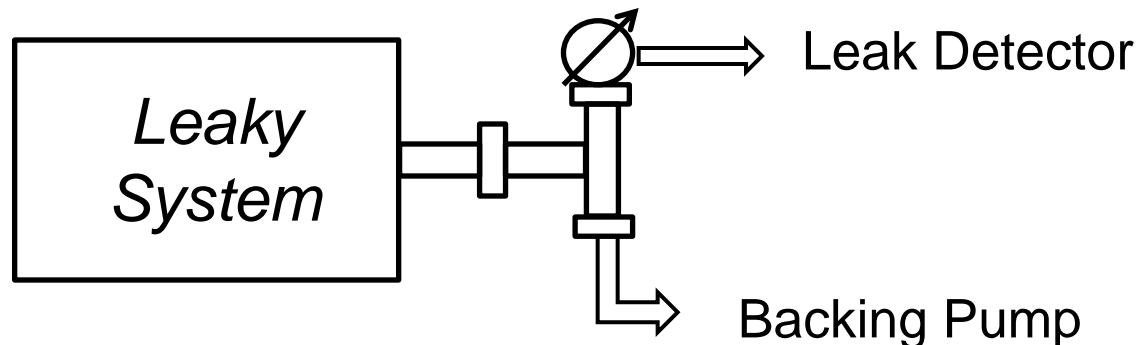

Locating a leak near multiple joints

- *It is sometime a difficult task trying to locate a leak at a location with multiple adjacent joints.*
- *Some of the tips are:*

1. *Use very small helium flow*
2. *Tapping/bagging*
3. *N₂ counter-flow/purging*
4. *Plugging potential leaks by solvent*
5. *Positive pressure test*

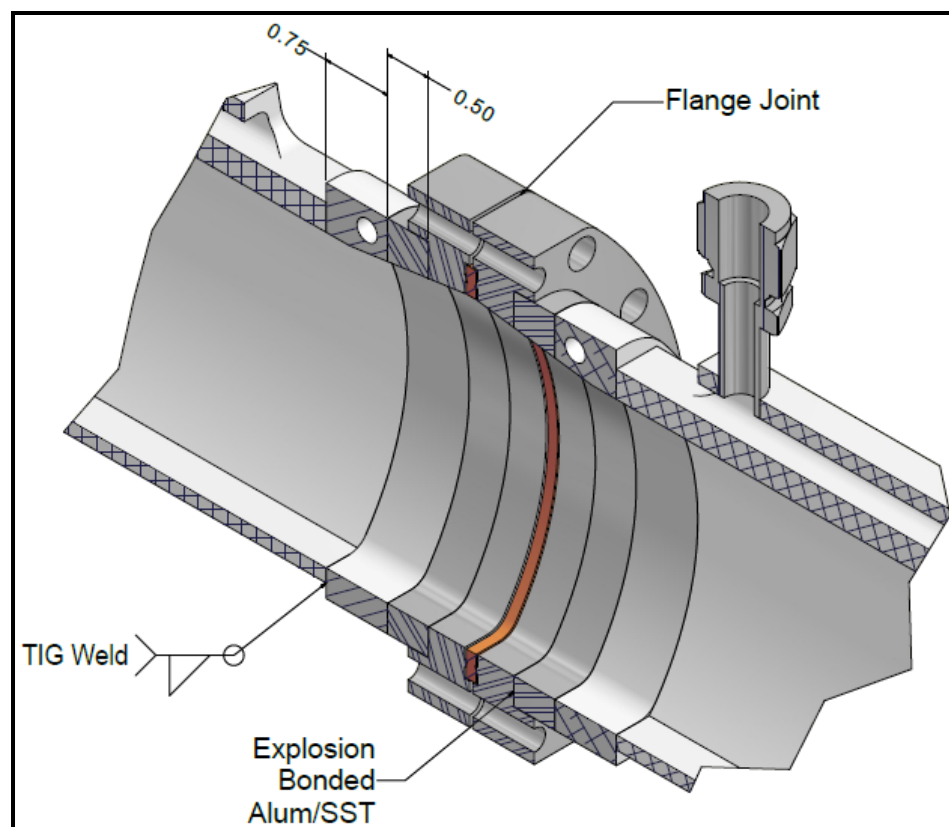



- Specification can include:
 1. Maximum allowable leak size
 2. Total maximum leakage rate (infers bagging)
 3. Component pressure during leak detection
 4. Type and sensitivity of the leak detector (e.g. MSLD with a sensitivity of 2×10^{-10} atm-cc of He/s)
 5. Use of certified standard leak immediately before and after testing
 6. Witness leak checking at fabrication site
- ASTM standards E432, E479, E493, E498, E499, and F97
- **If application is critical, witness the testing, or do it yourself**
- **Avoid phrases like; leak tight, vacuum tight, good to 10^{-8} Torr, good for ultrahigh vacuum, etc.**

Vacuum Chamber Bakeout



1. **Bakeout of high-vacuum and ultra-high vacuum components and chambers prior to installation is a key step in vacuum QC.**
 - Bakeout ensures that a vacuum component or a chamber is suitable for the vacuum requirement (in cleanness)
 - Controlled thermal cycling(s) in the bakeout may also expose leak(s) that may have been 'plugged' in the production leak checking

2. **Bakeout must be done with well established procedure.**
 - Bakeout must be done by well trained technician
 - All parts of a system should be heated evenly, to avoid thermal distortion. If possible, bakeout all components and chambers in an convection oven.
 - Bakeout temperature should set according to the materials. Stainless steels may be baked to as high as 450°C, aluminum normally to only 150°C (but never exceeding 180°C).
 - Temperature ramp-up and cooling-down rates must be slow enough to avoid permanent distortion, or gasket creeping. This is extremely important for a system with very un-even thermal mass distribution.
 - Vacuum pressure during bakeout should be recorded and documented. If possible, a RGA should be used. The duration of a bakeout is often determined by the pressure and RGA data trend.



1. In situ bake of installed systems: necessity?

- *in situ* bakeouts are generally necessary for systems static UHV/XHV conditions are required, and/or systems containing surface-sensitive component(s), particularly sensitive to H_2O , Examples include electron sources, proton/ion accelerator beam pipes, etc.
- NEG coated beampipes have to be activated by *in situ* heating.
- For systems dominated by dynamic gas load(s), such as SR-induced desorption, *in situ* bakeout may not be effective.

2. In situ bakeouts require careful planning and execution.

- Ideally, *in situ* bakeout requirement should be considered during the system design stage, to ensure compatibilities with other sub-systems, such as magnets.
- Similar bakeout procedures apply, with only much more cares, as the consequences are very severe for any errors and/or bakeout equipment malfunctions.
- For beampipes with good access, commercial heating tapes works well. However, many systems designed in heating elements onto the beam chambers for 'speedy' bakeout setup, such as CERN's LHC warm beampipes with NEG coatings, NSLS II's dipole chamber.
- In some cases with extreme space limitation, hot-water 'bakeouts' are also an option to reduce base pressure (mainly water partial pressure).

Bakeout – Heater Examples



NSLS II Beampipes

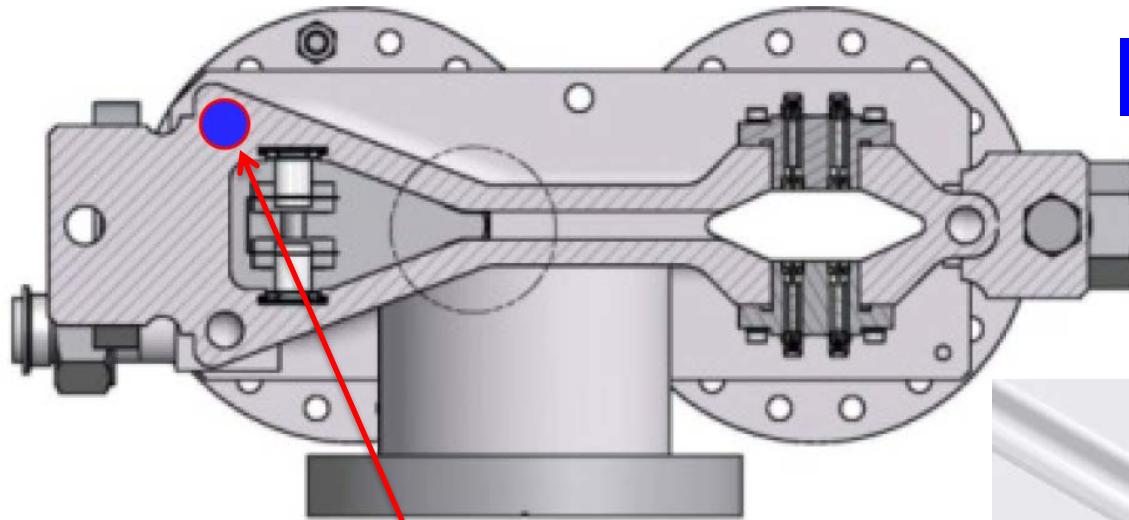

Build-in Cal-Rod heaters can be very simple and effective for in-situ bakeouts

CESR Beampipes

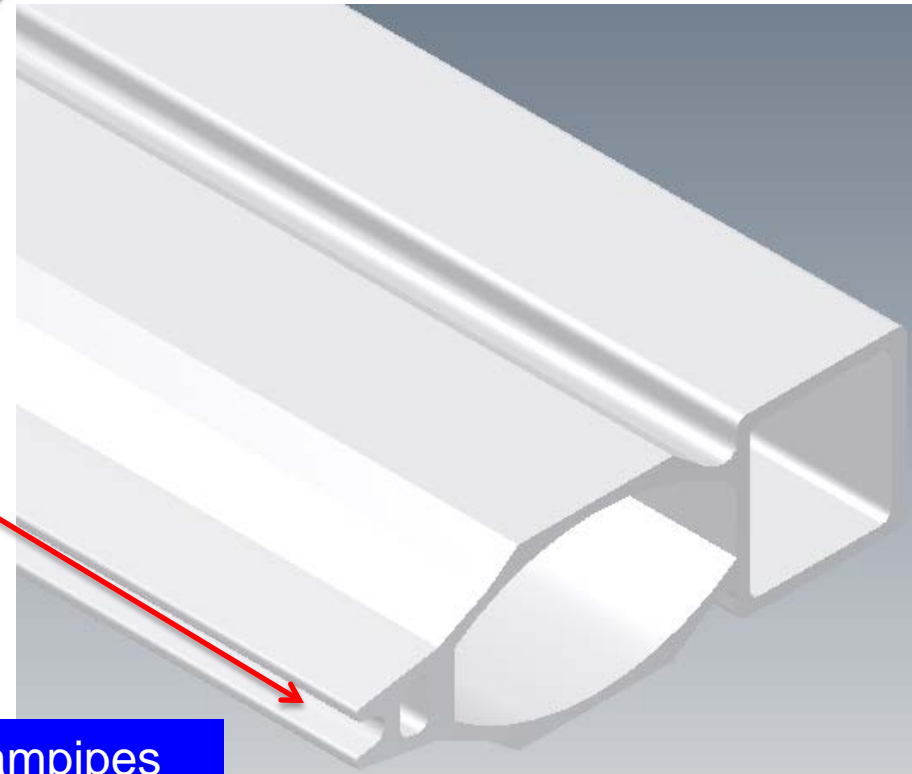

CERN LHC Low Profile Heaters

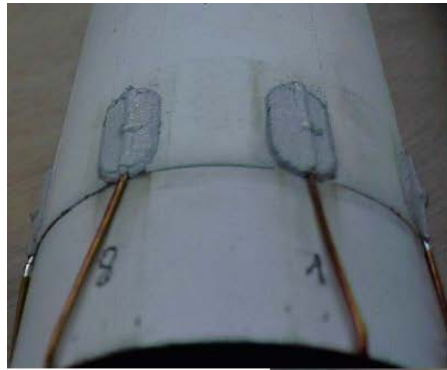

Thermal-Sprayed Heaters



Polyimide foil heater without top layer

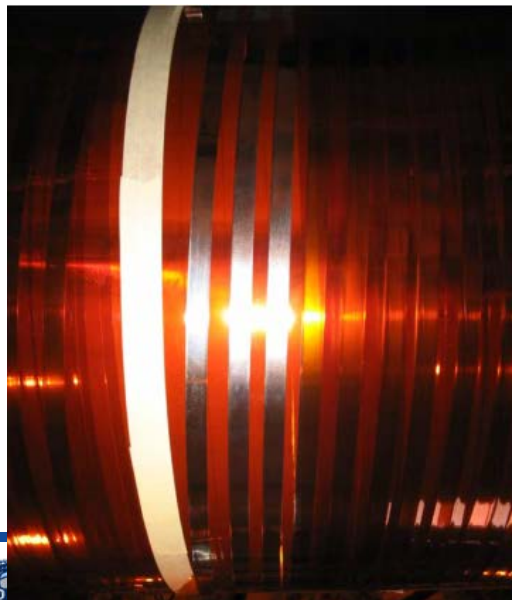

Wrapped Thin Tape Heaters







1. Vacuum system pumping down

- Majority of accelerator UHV systems need to be roughed down from atmospheric pressure to a level low enough to start ion pumps (or other types of capture pumps).
- Usually, oil-free (dry) TMP pumping systems are suitable for the roughing down.
- However, for systems sensitive to particulates (such as high-gradient superconducting cavities, photo-cathode electron guns, etc.), pumping rate must be carefully controlled to avoid moving particulates to the critical surfaces.

2. Vacuum system venting.

- Good venting method is a key in preservation of a baked or conditioned vacuum system, awarded with fast vacuum recovery upon re-pumping down.
- Being able to avoid in situ bakeout after vacuum interventions offers obvious benefit and flexibility in operations.
- The most common venting gas is DRY nitrogen. The typical sources of dry nitrogen are UHP cylinders and boil-off from LN₂ reservoir.
- Special chemical filters are often used to further reduce H₂O and HC contents in dry N₂ to below ppb level.
- At CERN LHC, filtered Ne gas is also used to vent and to purge activated NEG coated beampipes (*Proceedings of IPAC2011, San Sebastián, Spain, p.1557*)
- For particulate sensitive systems, venting rate must be carefully controlled to avoid moving particulates in the system.

DESY's Pumping/Venting System

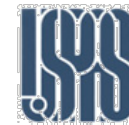

- DESY's studies indicated particle movement with ΔP down to 1 mbar!
- They developed a system using mass flow controllers for both pumping down and venting.
- The pumping/venting maybe controlled manually or automated electronically.
- The typical initial pumping/venting flow rates are 3 liter/min (N_2).
- At Cornell, a similar system is in use for 500 kV DC photo-cathode electron guns.

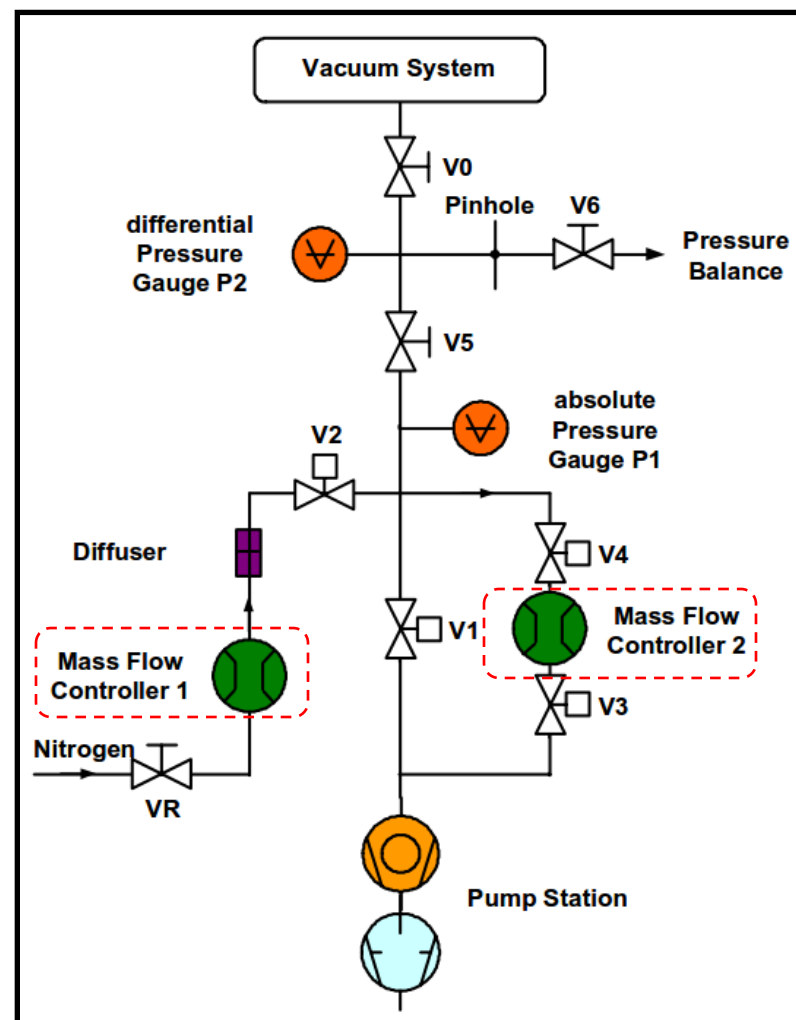

M. Bohnert, et al, "Particle Free Pump Down and Venting of UHV Systems", Proceedings of SRF2009, Berlin, Germany, p.883

CESR's Venting Filter Manifold

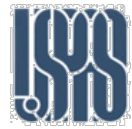

- Both our CESR vacuum and ERL vacuum systems have been using a chemical filters (widely used in Semi-Industry) for venting. All fittings are converted to self-sealed quick connects to keep the manifold clean, and to minimize saturation of the filters.
- Significantly improvements in vacuum recover are observed after using the filtration systems.

Self-Sealed Quick Connects

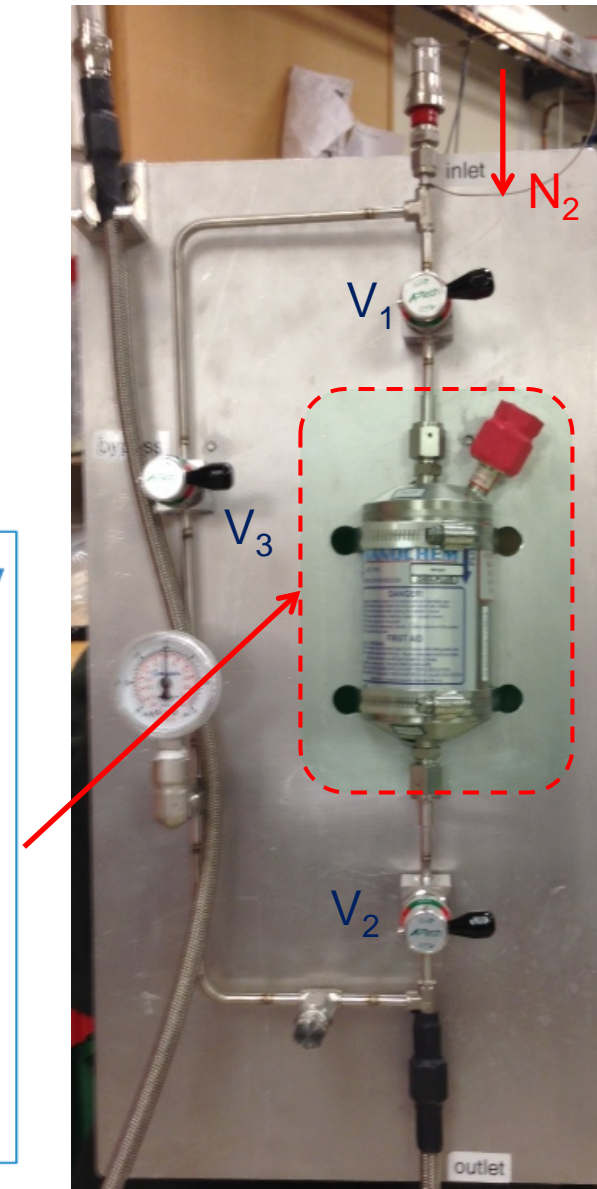
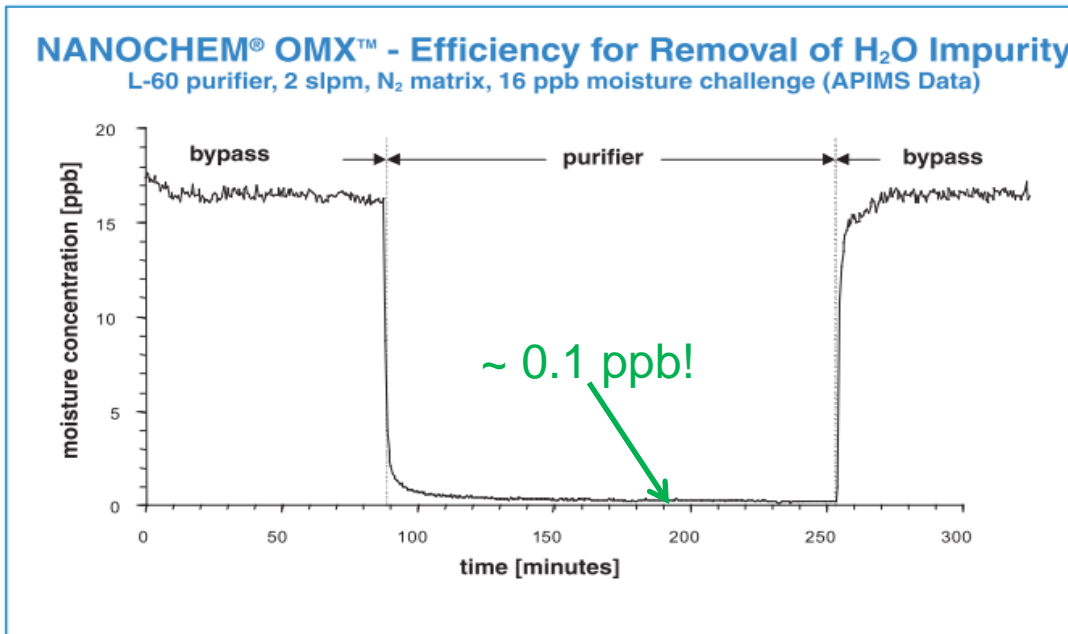

CESR Electron Gun Pumping Downs



Two Gun Cathode Replacements

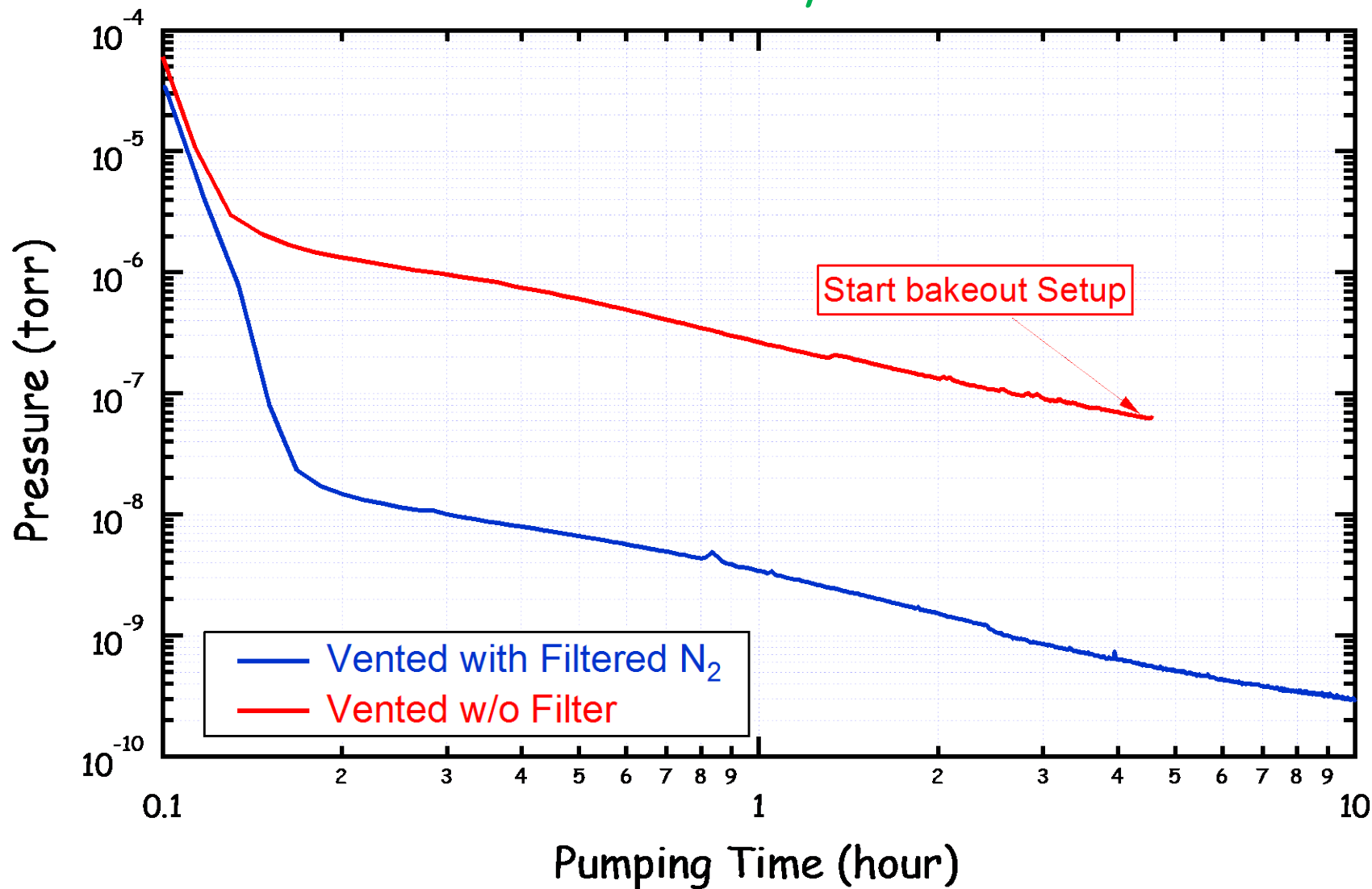

Vacuum Instrumentation, Control and System Protection

Sectoring an Accelerator Vacuum System



- ❑ *Vacuum systems for large accelerators (circular or linear) are sectored by gate valves, to provide flexibility in accelerator upgrades, maintenance and repairs.*
- ❑ *The lengths of sections are often determined complexity of components in a section. For simple particle beam transport beamlines, sections as long as over 20-m. However, operational critical and/complex sub-systems are gate valved, such as RF cavities, SR-producing insertion devices, etc.*
- ❑ *For high intensity, short bunched beams, the gate valves must be RF-shielded. These gate valves are usually all-metal styles, though UHV RF-shielded GVs with Viton O-ring gate seals are also used (such as in CESR).*
- ❑ *The sectoring GVs are interlocked by ready-chains that including vacuum signals, as a part of accelerator machine protection system.*



- ❖ *Ion gauges (hot-cathode or/and cold-cathode) are evenly distributed throughout the accelerator vacuum systems as the main total pressure gauges in accelerator operations.*
- ❖ *The ion gauge controllers communicate to the accelerator control system for data logging, vacuum system status monitoring.*
- ❖ *As the vacuum pumping system, ion pumps are installed around accelerator vacuum system, usually more dense than the ion gauges. Thus the ion pump currents can also be used as vacuum pressure monitors.*
- ❖ *It is strongly recommended to have one RGA installed in each sector. The RGAs are important tools in vacuum system trouble-shooting, and vacuum system performance diagnostics.*
- ❖ *A high pressure gauge, such as a Convectron-Pirani gauge, must be installed in each vacuum sector, to be included in the vacuum system interlock. In major vacuum incident involving air rush-in, ion gauges and ion pumps may show "UHV-condition"!*

Gate Valve Ready-Chain – CESR Example



- ❑ Gate valves are interlocked by (at least) vacuum status of the vacuum sectors on both sides of the gate valves, via a so-called ready-chain.
- ❑ Gate valve ready chains should be implemented at low-level controls, that is, should not rely on a computer/software.
- ❑ At CESR, gate valve a Rough Vacuum, and two ion pumps in parallel. Hard-wired.

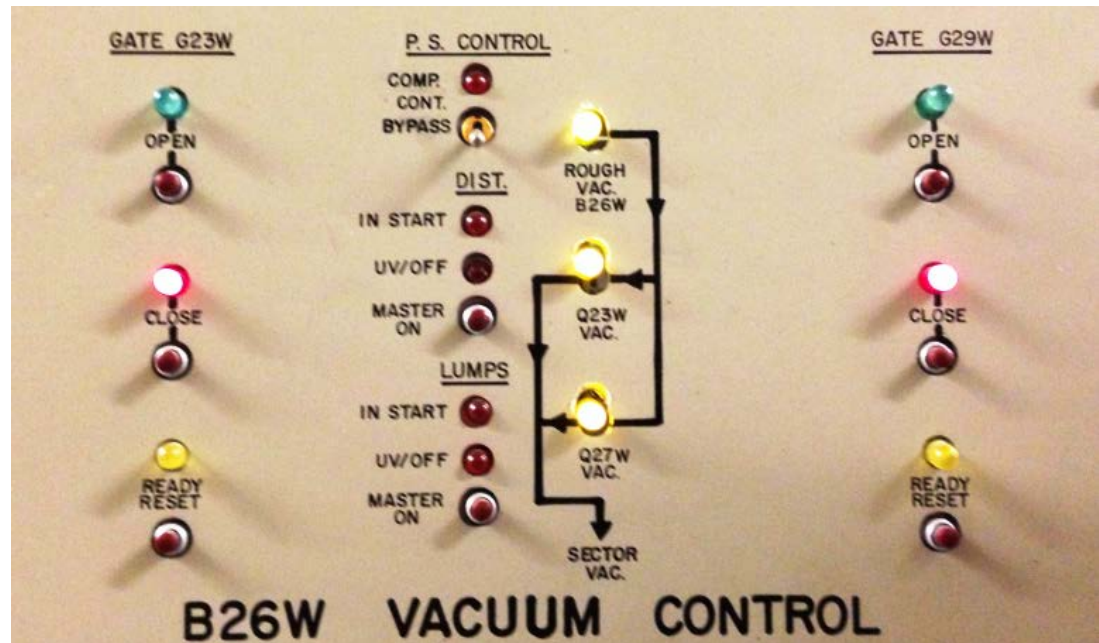

X-ray Beamline Instrumentation – CHESS



- ❑ For light source beamlines, proper vacuum instrumentation and interlocks must be in place to provide flexibility to X-ray users, while protecting accelerator vacuum system and operations.
- ❑ During X-ray operations, any beamline may be isolated by a pair of beam stops and down-stream gate valves.
- ❑ A fast gate valve and sufficient delay-line and differential pumping prevent potential contaminations of accelerator UHV system from X-ray users' samples.

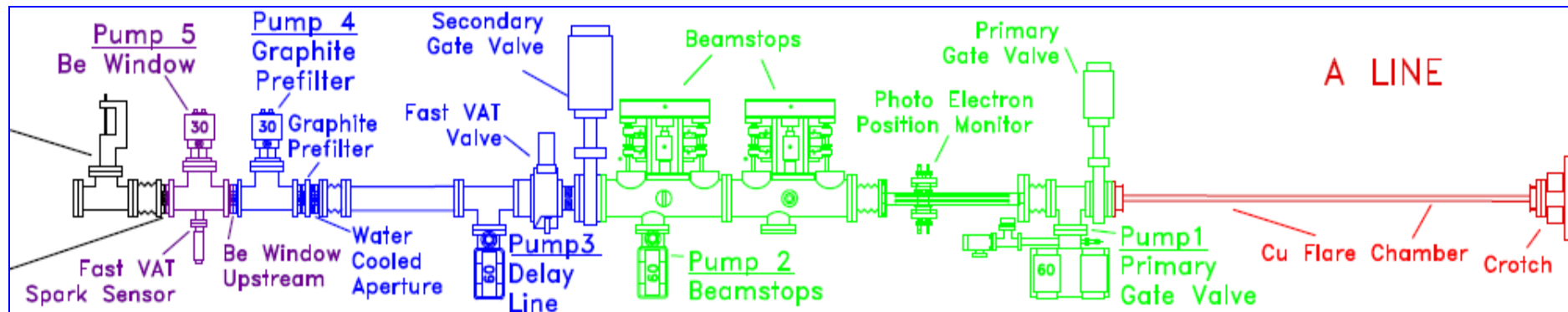
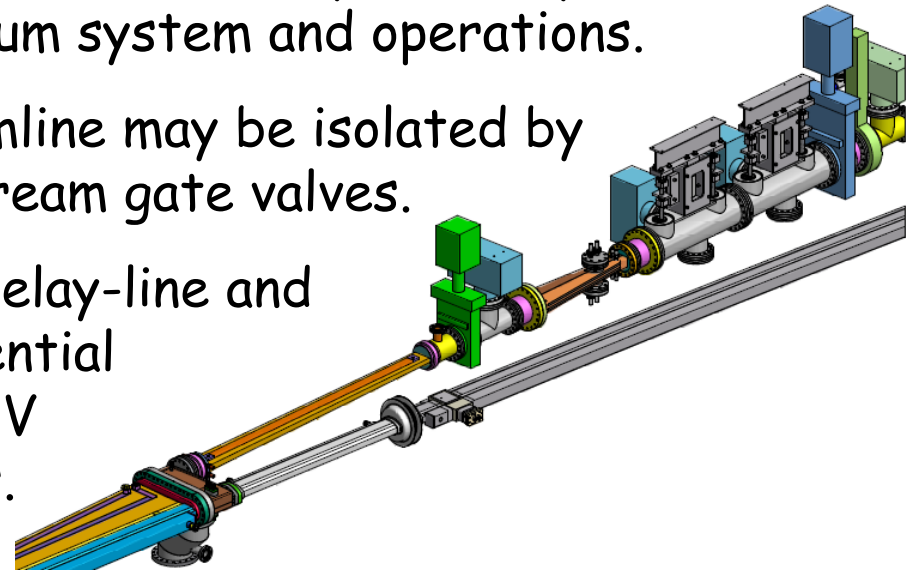

Vacuum System Thermal Protection

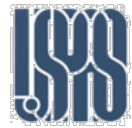

- ❑ *For high beam current storage rings, vacuum chamber walls are subject to very high SR power area density. Adequate water cooling are normally build in to handle the SR power, to keep temperature rise and associated thermal stress below a safe level.*
- ❑ *Thermocouples are usually attached to the vacuum chambers to ensure that there are normal cooling water flows, and to warn any mis-steering of the electron beam.*
- ❑ *The temperature monitoring also helps identify any abnormal heating, such as unexpected HOML (broken RF fingers, excitation of trapped modes, etc.).*
- ❑ *In CESR, close to 800 TCs are attached to the vacuum chambers. Warning limits are implemented for all the TCs, and a 'watch-dog' program will warn operators of any higher-than-limit temperatures.*
- ❑ *At CESR, we also installed micro-switches on all water valves, and the CESR Control System checks that all valves are opened after maintenances to the system.*

Examples of TC locations in CESR

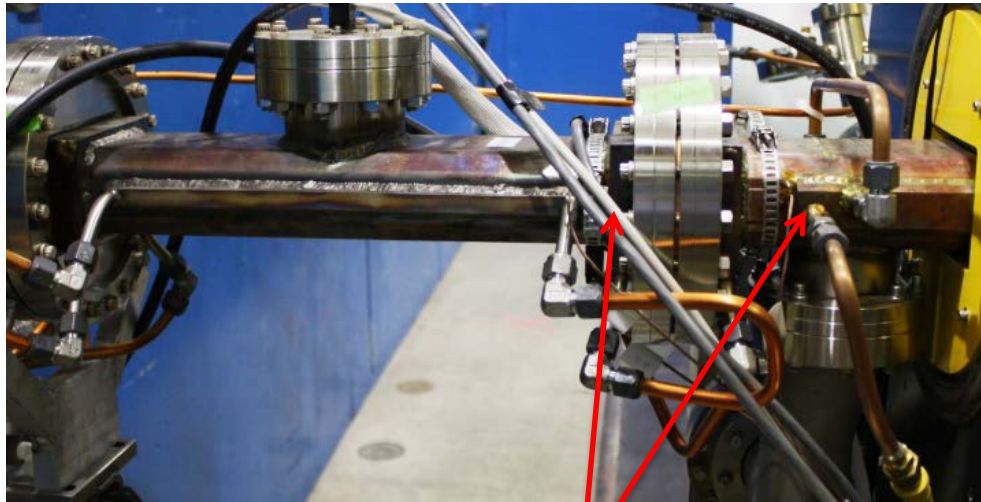

TCs between cooling, most common locations. Many clogged lines, dead-looped plumbing were “discovered” by the TCs.

Multiple TCs to detector beamline misalignment, mis-steering, etc.

CEHSS Crotch

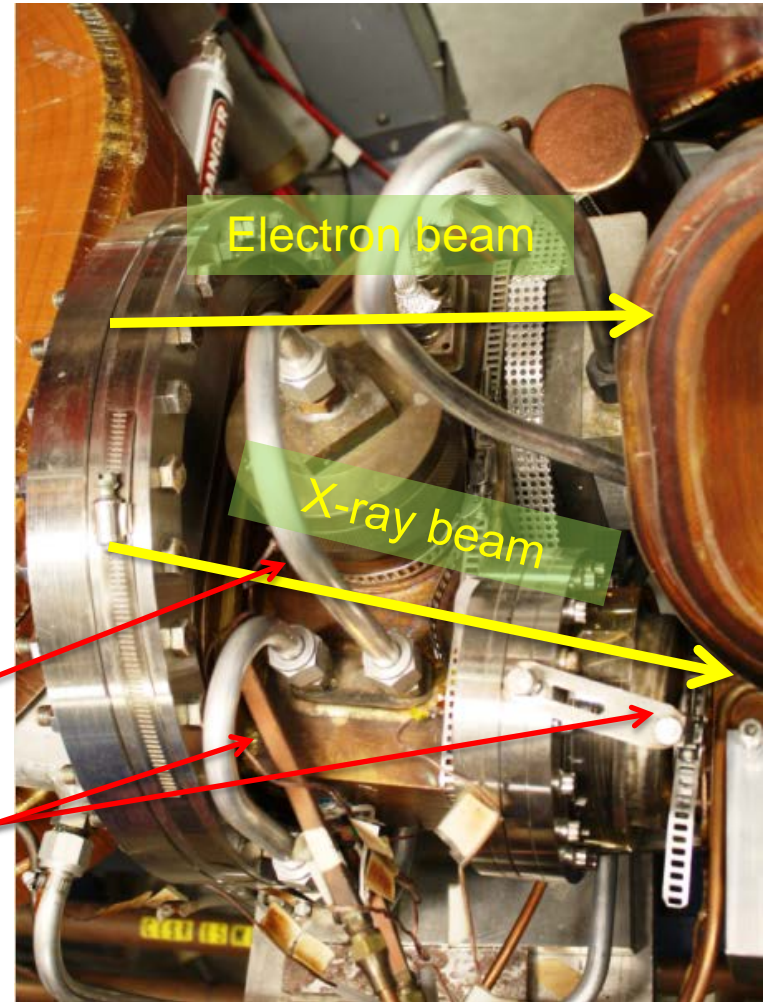

Examples of TC locations in CESR Cont.



TCs at locations where higher-order mode loss (HOML) may occur

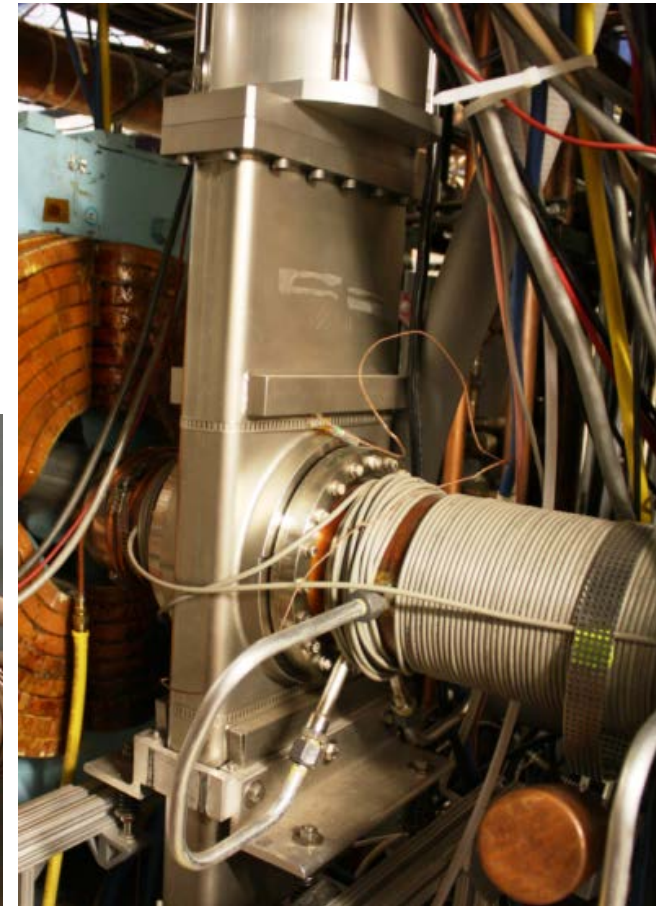

Examples of TC locations in CESR Cont.

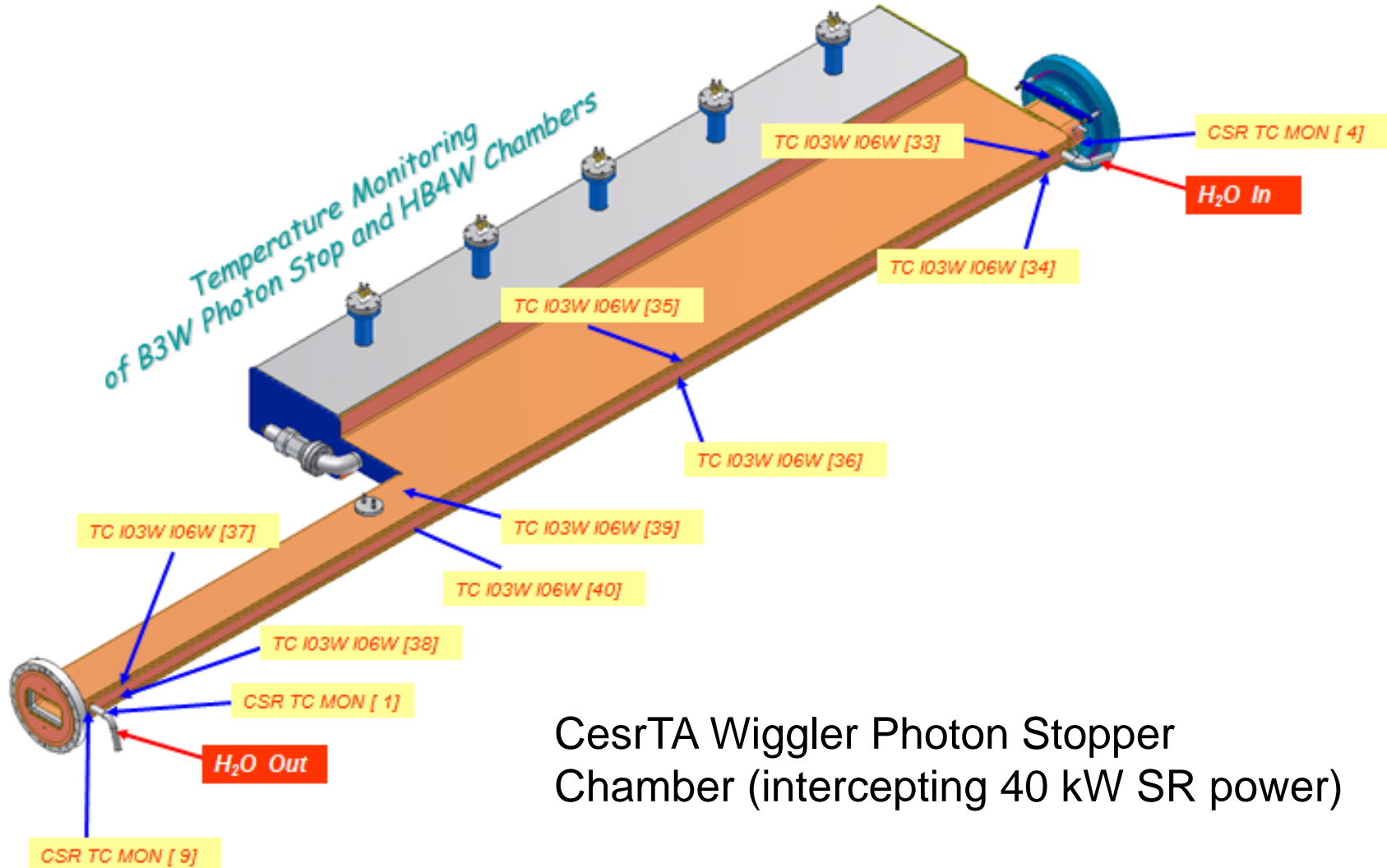

Important to understand heating patterns

- ❖ In early stage of Cornell ERL prototype injector high current operations, we noticed the ('minor') uneven beam dump heating, but did not take it seriously.
- ❖ We learned our lesson. As a result of incorrect dump beam setup, electron beam was not rastering in circular pattern, but in a vertical linear pattern.

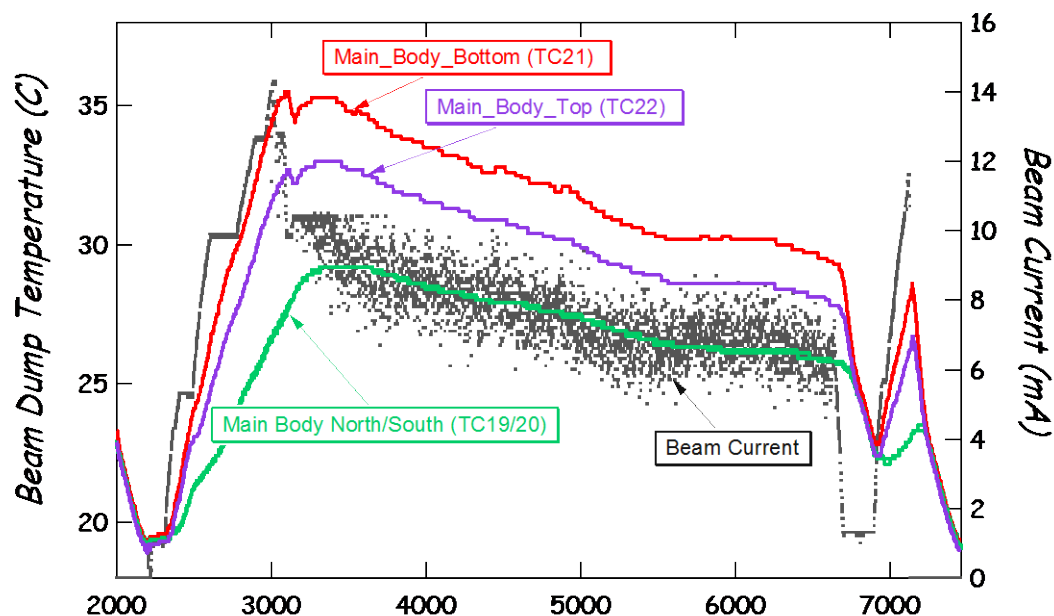
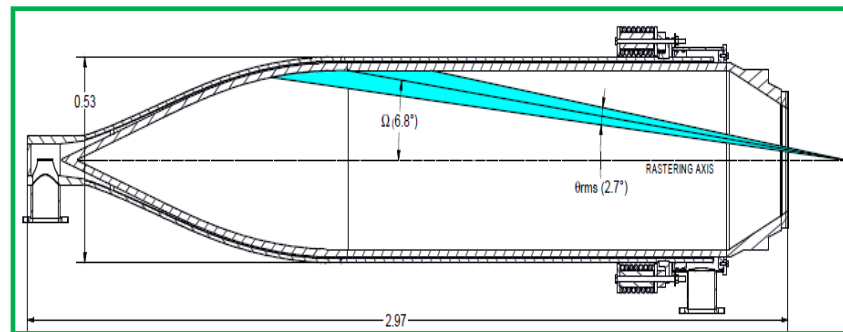

Electron beam melted through aluminum body

Ion Pump Feedthrough Protection

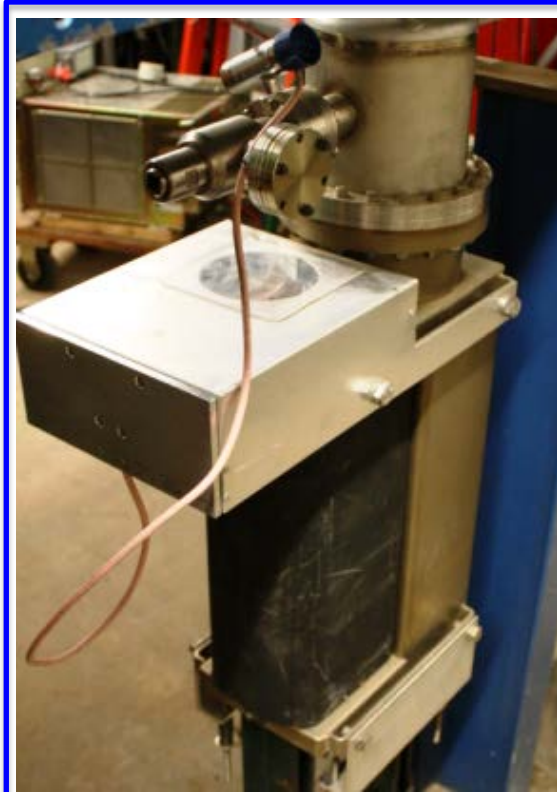

HV feedthroughs of ion pumps are most vulnerable, needing protection

HV feedthroughs of ion pumps near cryogenic systems (such as SRF cavities here) need special care, to prevent condensation. Dry N₂ purging are used in CESR.

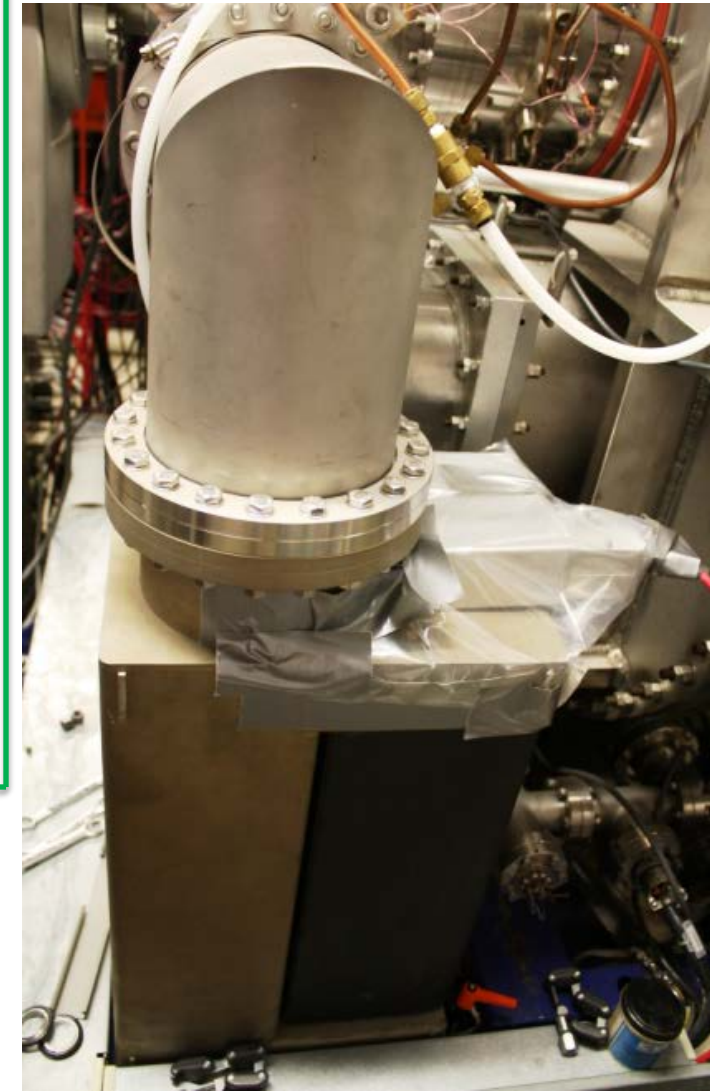

CESR Vacuum Performance – Snapshot



1	C2W1	0.1	0.2	nTorr	2	C2E1	0.1	0.3	nTorr
3	C2W2	0.1	0.2	nTorr	4	C2E2	0.1	0.3	nTorr
5	C2W3	0.1	0.6	nTorr	6	C2E3	0.1	0.5	nTorr
9	SB3W	0.1	0.6	nTorr	10	SB3E	0.1	0.3	nTorr
11	CB3W	0.1	0.5	nTorr	12	CB3E	0.1	0.4	nTorr
13		0.1	0.1	nTorr	14	C03E	0.1	0.5	nTorr
15	CH4W	0.5	1.2	nTorr	16	CH5W	0.3	0.9	nTorr
17	CH5E	0.4	1.3	nTorr	18		0.1	0.1	nTorr
19		0.1	0.1	nTorr	20	C07W	0.2	0.8	nTorr
21	C07E	0.2	0.5	nTorr	22	C08W	0.4	1.1	nTorr
23	C08E	0.5	1.1	nTorr	24	W1CC	0.2	0.5	nTorr
25	E2CW	0.2	0.5	nTorr	26	W1RB	0.3	0.4	nTorr
27	W1WD	0.5	0.9	nTorr	28	E2RB	0.2	0.3	nTorr
29	E2WD	0.2	0.3	nTorr	30	WRFC	0.3	0.5	nTorr
31	ERFC	0.3	0.5	nTorr	32	W2WD	0.2	0.1	nTorr
33	W2RB	0.4	0.6	nTorr	34		0.1	0.1	nTorr
35	E1WD	0.4	0.5	nTorr	36	W2CW	0.3	0.4	nTorr
37	E1CC	0.1	0.6	nTorr	38	C09W	0.4	0.8	nTorr
41	Q14W	0.5	2.8	nTorr	42	C11W	0.0	0.6	nTorr
43	CHG1	0.0	0.0	nTorr	44	B13W	0.4	1.5	nTorr
45	B13E	0.4	1.1	nTorr	46	B18W	0.5	2.0	nTorr
47	B16E	0.2	1.9	nTorr	48	B15W	0.5	1.6	nTorr
49	B15E	0.3	1.4	nTorr	50	B18E	0.3	0.9	nTorr
51	B20E	0.1	0.1	nTorr	52	Q19W	0.0	0.0	nTorr
53	B20W	0.2	0.9	nTorr	54	Q20W	0.2	0.9	nTorr
55	B21W	0.3	0.8	nTorr	56	B21E	0.3	1.2	nTorr
57	Q21W	0.1	0.6	nTorr	58	B22W	0.2	0.9	nTorr
59	Q22W	0.2	0.7	nTorr	60	B23W	0.3	0.6	nTorr
61	Q23W	0.3	2.5	nTorr	62	C23E	0.2	0.6	nTorr
63	C29W	0.3	2.0	nTorr	64	C29E	0.3	1.5	nTorr
65	C33W	0.4	1.5	nTorr	66	C33E	0.2	1.1	nTorr
67	C39W	0.2	0.6	nTorr	68	B38E	0.3	0.5	nTorr
69	C44W	0.7	2.2	nTorr	70	C44E	0.7	1.9	nTorr
71	C48W	0.5	1.7	nTorr	72	S48E	0.3	0.5	nTorr
73	N48E	0.4	0.6	nTorr	74	C49E	0.3	1.0	nTorr

200 mA

No beam

CESR Vacuum Performance - dP/dI



CESR Vacuum Operation Status -- dP/dI Plot

- Vacuum [Conditioning](#) after Summer 2012 CESR Shutdown
- Vacuum [Conditioning](#) after Winter 2011-12 CESR Shutdown
- Vacuum [Conditioning](#) after Summer 2011 CESR/Cesr Shutdown
- Vacuum [Conditioning](#) after January 2011 CESR/Cesr Shutdown
- Vacuum [Conditioning](#) after Spring 2010 CTA-shutdown
- Vacuum [Conditioning](#) after June 2009 CTA-shutdown
- Vacuum [Conditioning](#) after Summer 2008 CTA-shutdown
- B12W sector [Conditioning](#) after installation of RFA dipole and replace Q14W SC wigglers in June 2008.
- L3 Vacuum [Conditioning](#) after installation of RFAs in March 2008
- Vacuum [Conditioning](#) after June 2006 Shutdown
- Vacuum [Conditioning](#) after January 2006 Shutdown
- Vacuum [Conditioning](#) after June 2005 Shutdown
- Vacuum [Conditioning](#) after the Summer'04 FLM Shutdown
- [Conditioning](#) after the Spring '04 Shutdown (06/24-11/10/04)
- [Conditioning](#) after the Spring '03 Shutdown (07/10-12/10/03)
- [Conditioning](#) from the Summer '02 Shutdown (09/12-11/10/02)
- Phase III (SCIR) Operations (10/10/01-2/28/02), after [Shutdown](#)
- [SC IR](#) | [West HBs](#) | [SRF Regions](#)
- [Phase 2/3](#) Operations (4/1/00-2/28/01)
- [Phase II](#) Operations (11/95-12/98)

